

USER GUIDE

High performance BB servo motor

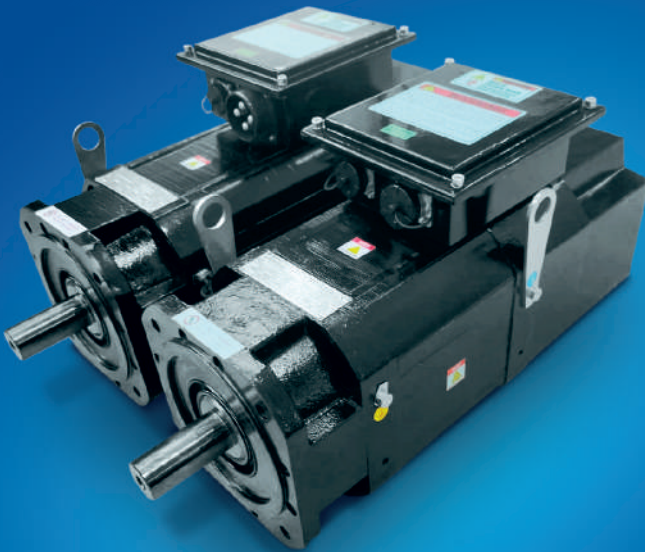

IFU: Information For Use

COPYRIGHT

ALL RIGHTS RESERVED

This User's Guide ("Guide") along with all its contents is the sole property of Bharat Bijlee Ltd ("BBL"). It is delivered to others on the condition that it shall be used only by the purchaser of BBL's Servo Motor or his authorized agent who shall follow all operating instructions and installation guidelines stated therein to ensure correct and accurate installation of the said Servo Motor. BBL shall not hold any responsibility unless installation of the Servo Motor is carried out in strict accordance with the instructions laid down in this Guide.

This User Guide may not be copied, reproduced, republished, sold, downloaded and posted, broadcast or transmitted in any way except with the prior written permission of BBL.

BBL reserves the right to make changes in the Guide and its contents without prior intimation/notice.

Any dispute arising out of this Notice shall be subject to Indian Laws and to the exclusive Jurisdiction of the courts in Mumbai, India.

INDEX

1. GENERAL INFORMATION	4
1.1. Synchrotorque Servo Motor	4
1.2. Objective	4
1.3. Checking	4
2. SAFETY INSTRUCTIONS & PRECAUTIONS	5
3. PRODUCT INFORMATION	8
4. MARKING AND IDENTIFICATION DETAILS	9
4.1 Dimensions	10
4.2 Technical specifications	11
4.2.1 Technical specifications STS-050-2500-215B-F-K	11
4.2.2 Technical specifications STS-070-2500-215B-F-K	13
4.2.3 Technical specifications STS--090-2500-215B-F-K	15
5. PRE COMMISSIONING	17
5.1. Cooling fan	17
5.2. Shaft Load precautions	17
5.3. Mounting	17
5.4. Environmental	17
6. ELECTRICAL CONNECTION	18
6.1. Earthing	18
6.2. Connection Diagram	19
7. INSTALLATION	20
7.1. Before starting machine	20
8. TROUBLESHOOTING	21
9. DOS & DON'TS	22
10. WARRANTY	24
11. LIST OF ACCESSORIES	26
12. CERTIFICATION	30

1. GENERAL INFORMATION

1.1. SynchroTorq® Servo Motor

Congratulations!! for buying BBL servo motors.

SynchroTorq® is a Bharat Bijlee's new brand name under which the permanent magnet synchronous motors are manufactured. For the direct drive segment all the machines at MTM division are manufactured under this brand.

• **Please preserve this User Guide. Store this user guide carefully for future reference.**

1.2. Objective

This Guide provides technical information about the characteristics of servo motors, its intended use, product information. It also includes directions on mounting, installation, troubleshooting and maintenance.

This Guide should be read by all installation and maintenance teams & all instructions therein be strictly followed before attempting the Installation.

For further information, suggestion and clarification, please contact Bharat Bijlee, mtmsales@bharatbijlee.com or visit www.bharatbijlee.com.

1.3. Checking

Please check the rating of the motor after opening the packing and confirm that it is in accordance with your order.

The packing of the servo motor contains the servo motor, routine test certificate, installation manual and warranty card.

If you observe product damaged during the transportation, please inform Bharat Bijlee immediately.

The machines are to be used and operated by the authorized trained persons only.



2. BB SERVO MOTOR - GENERAL WIRING, CAUTION, SAFETY INSTRUCTIONS & PRECAUTIONS



The instructions given in this manual or any other instructions supplied must always be observed to avoid danger or damage.



 **WARNING / CAUTION:** This indicates noncompliance with the instructions and can lead to personal injury and product damage.

The mounting, installation, and maintenance of the SERVO motor, is allowed only to qualified and trained personnel.

Following the safety at work regulations and general recommendations.

 WARNING	<ul style="list-style-type: none"> • The machines are not designed for direct connection to the three-phase system; but are to be operated via an electronic frequency converter. Direct connection to the system may destroy the motor. • Strictly follow the installation check points • Ensure that power & control cables are not damaged, stressed loaded, or pinched and properly secured to respective motor terminals /connectors. • Ensure that motor is provided with proper earthing connection • Ensure that the terminal box is properly closed before powering the motor. • Do not open the terminal box cover when the motor is powered.
 CAUTION	<ul style="list-style-type: none"> • It is mandatory to provide proper access to the motor for maintenance purpose. • Only the voltage specified on nameplate should be applied to corresponding terminals to prevent unwanted electrical hazards and damage to motor parts. • During operation, never touch the rotating parts of the servo motor. Doing so can cause injury.

 WARNING	<ul style="list-style-type: none"> • Transport the products correctly according to their weights mentioned in nameplate/catalogue. • Lifting plates provided by the manufacturer must be used to lift and transport the servo motor only. • Do not lift/ carry the servo motor by the cables, shaft or terminal box. • Do not put heavy objects on servo motor. • Do not install or operate the servo motor which has been damaged or has any parts missing • Do not block the air intake/exhaust port of the servo motor having cooling fan. • Do not drop or strike servo motor. • Never hit the servo motor or shaft, especially when coupling the servo motor to the load. The encoder/resolver may become defective.
 CAUTION	<ul style="list-style-type: none"> • Ensure that no temperature sensitive external parts / objects are in contact with the motor body as the motor body temperature rises during the motor operation. Protection against accidental contact should be provided, if required. • Ensure that the power & control connections to the motor are proper to prevent over heating due to loose connections.
 CAUTION	<ul style="list-style-type: none"> • Before powering the motor, ensure that the drive parameters are properly programmed as per motor details. Improper settings may cause undesired operation / malfunction.



 WARNING	<ul style="list-style-type: none">• Always store the servo motor indoors in a clean and dry place.• If the insulation resistance of the winding decreases, reexamine the storage method.• Though the servo motor is rust-proofed before shipment using paint or rust prevention, rust may be produced depending on the storage conditions or storage period.• If the servo motor is to be stored for longer than six months, apply rust prevention oil especially to the machined surfaces of the shaft, etc.• If the motor is stored for extended period, ensure to turn the motor shaft rotates freely using hand, before using the motor.• When the motor has been stored for an extended period of time, consult BBL.
 CAUTION	<ul style="list-style-type: none">• Do not dismantle the servo motor without consulting BBL.• The motor and the accessories are to be used as per its intended use as mentioned in the user guide, IFU document.

3. PRODUCT INFORMATION

3.1. Name Plate

The name plate is stuck on the machine, It includes some necessary parameters for setting frequency inverter. Please refer the parameters for frequency inverter setting.

For Example:

 Bharat Bijlee SynchroTorq™			PMS SERVO MOTOR No. 2. MIDC AIROLI NAVI MUMBAI 400708 INDIA		
Model: STS-090-2500-2150-F-K			M/C NO: S2300559		
Torque	Current	RPM	Freq	Max RPM	FAN
90 Nm	50,000 A	2500	125.0 Hz	3200	1Ø 230 V
Voltage	Cooling	Power	Feedback	Weight	KTY/PTC
Y 370 V	IC 416A	23.55 kW	Resolver	87 kg	YY

3.2. Nomenclature

STS XX-XXXX-XXXX- X- X

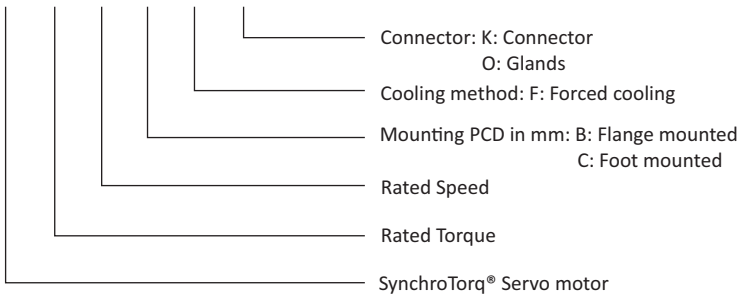

e.g. STS-090-2500-112B-F-K

Nomenclature for Servo Motors					
STS	090	2500	112B/C	F	K
SynchroTorq® Servo	Rated Torque	Rated Speed	Mounting PCD B-Flange Mounted C-Foot Mounted	Fan Forced cooling F-IC	Connector K-With connectors O-No connectors

4. MARKING AND IDENTIFICATION DETAILS

Sr. No.	Marking	Details
1	Manufacturer's name or mark	Provided on name plate
2	Serial no. or identification mark	Serial no of the machine provided on the name plate.
3	Year of manufacturing	First two letters indicate year of manufacture
4	Manufacturer's machine code	Available on name plate
5	No. of phases	It is a single phase or three phase system provided on name plate.
6	Performance STD	Available on name plate
7	Degree of protection	Available on name plate
8	Method of cooling	Available on name plate
9	Thermal Class	Available on name plate
10	Rated output	Available on name plate
11	Rated Voltage	Available on name plate
12	Rated Frequency	Available on name plate
13	Open circuit voltage	–
14	Rated current	Available on name plate
15	Rated Speed	Available on name plate
16	Permissible overspeed	20% more than rated speed
17	Rated power Factor	0.9
18	Rated ambient temperature	45° C
19	Min ambient temperature	-10 °C
20	Altitude	1000m
21	Total mass of the machine	Mentioned on name plate
22	Direction of rotation	Machine operates on both CW and CCW directions
23	Connecting instructions	Provided inside the T box cover
24	Starting requirements	Provided in IFU

4.1 Dimensions

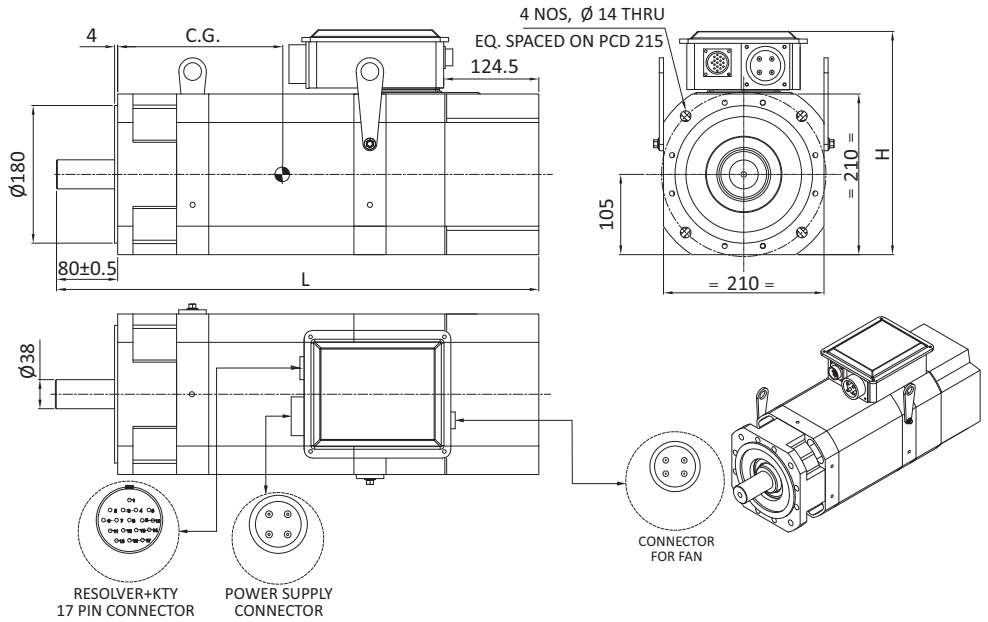

Model	L (mm)	H (mm)	CG (mm)	Wt. (kg)
STS-050-2500-215B-F-K	563	300	179	69
STS-070-2500-215B-F-K	603	300	199	78
STS-090-2500-215B-F-K	638	310	216	87
STS-115-2500-215B-F-K	673	310	233	97

4.2 Technical Specifications

4.2.1 Technical specification for servo motor STS-050-2500-215B-F-K

SPECIFICATIONS	
Model	STS-050-2500-215B-F-K
Rated Specification	
Rated RPM	2500
Rated Nm	50
Rated kW	13.08
Rated Amp.	27
Vrms (rated operating voltage)	360
Kt (torque constant)	1.85
Vs/1000 (back EMF constant)	128
Overload Specification	
Max Nm	105
RPM at max torque	2500
Amp. At max torque	62
Over speed Specification	
Max RPM	3200
Nm at max RPM	40
Mechanical Specification	
Shaft Dia in mm	38
PCD in mm	215
Inertia 10 ³ kgm ²	11.39
Other Features	
Insulation Class	H
Temp Rise	110 K
PTC Tripping	160°C
KTY Qty	1 no's
Fan	Single phase 230 V
Resolver	2 Pole, 1024 PPR
Connector	Yes (Fan, Resolver, Power Supply, KTY, PTC)
Weight	73 kg
IP	54
Mounting Type	Flange type, 4 mm Spigot
Color	BLACK RAL 9017
Ambient temp	45 °C
Shaft	Key less shaft, 80 mm Extension

• Torque Speed Curve:

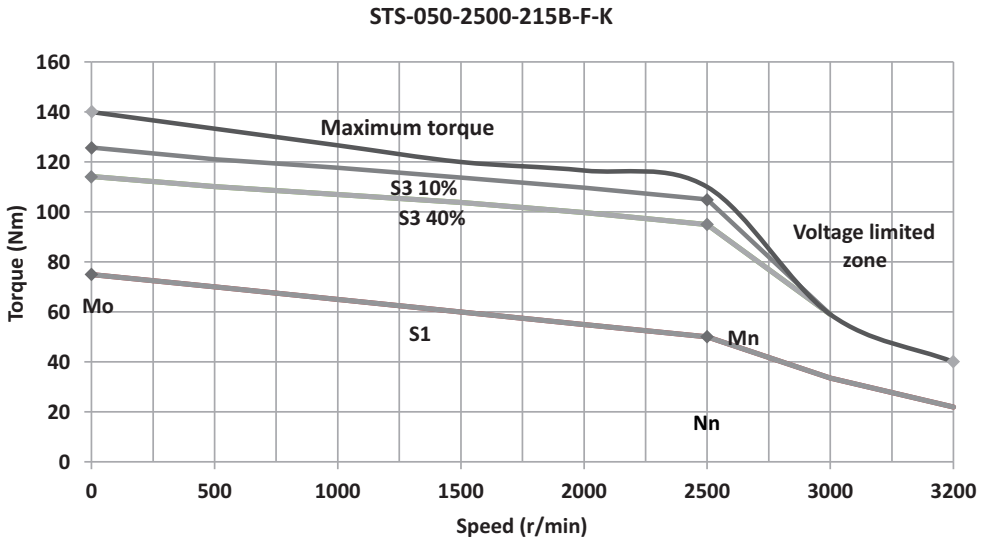

Notes:

1. **Mo** is standstill torque & **Mn** is the rated torque at rated speed **Nn**
2. S1 duty, S3 40% & S3 10% duty temp rise = 110 K
3. In peak condition that is max torque, motor can withstand for 15 to 20 sec, but also need to consider bear time of drive.

• **Basic requirements for safe & proper operation :**

1. Proper earthing at min. two points should be given to the motor.
2. Proper air ventilation needs to be provided to avoid overheating of motor.
3. All other standard procedures and practices to be followed.

4.2.2 Technical specification for servo motor STS-070-2500-215B-F-K

SPECIFICATIONS	
Model	STS-070-2500-215B-F-K
Rated Specification	
Rated RPM	2500
Rated Nm	70
Rated kW	18.32
Rated Amp.	39
Vrms (rated operating voltage)	370
Kt (torque constant)	1.79
Vs/1000 (back EMF constant)	122
Overload Specification	
Max Nm	165
RPM at max torque	2500
Amp. At max torque	94
Over speed Specification	
Max RPM	3200
Nm at max RPM	54
Mechanical Specification	
Shaft Dia in mm	38
PCD in mm	215
Inertia 10 ³ kgm ²	14.21
Other Features	
Insulation Class	H
Temp Rise	110 K
PTC Tripping	160°C
KTY Qty	1 no's
Fan	Single phase 230 V
Resolver	2 Pole, 1024 PPR
Connector	Yes (Fan, Resolver, Power Supply, KTY, PTC)
Weight	78 kg
IP	54
Mounting Type	Flange type, 4 mm Spigot
Color	BLACK RAL 9017
Ambient temp	45 °C
Shaft	Key less shaft, 80 mm Extension

• Torque Speed Curve:

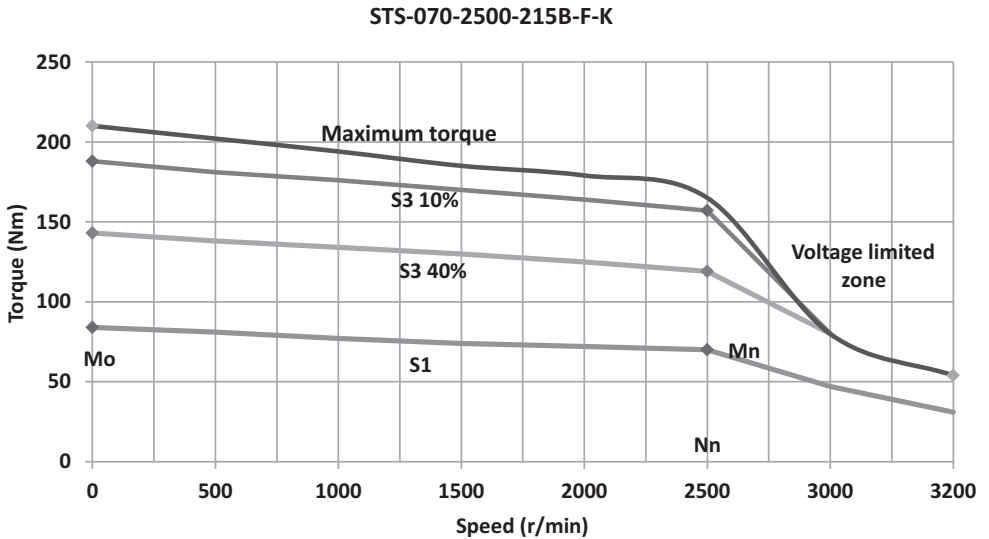

Notes:

4. **Mo** is standstill torque & **Mn** is the rated torque at rated speed **Nn**
5. S1 duty, S3 40% & S3 10% duty temp rise = 110 K
6. In peak condition that is max torque, motor can withstand for 15 to 20 sec, but also need to consider bear time of drive.

• **Basic requirements for safe & proper operation :**

4. Proper earthing at min. two points should be given to the motor.
5. Proper air ventilation needs to be provided to avoid overheating of motor.
6. All other standard procedures and practices to be followed.

4.2.3 Technical specification for servo motor STS-090-2500-215B-F-K

SPECIFICATIONS	
Model	STS-090-2500-215B-F-K
Rated Specification	
Rated RPM	2500
Rated Nm	90
Rated kW	23.55
Rated Amp.	50
Vrms (rated operating voltage)	360
Kt (torque constant)	1.8
Vs/1000 (back EMF constant)	122
Overload Specification	
Max Nm	208
RPM at max torque	2500
Amp. At max torque	118
Over speed Specification	
Max RPM	3200
Nm at max RPM	58
Mechanical Specification	
Shaft Dia in mm	38
PCD in mm	215
Inertia 10³ kgm²	16.6
Other Features	
Insulation Class	H
Temp Rise	110 K
PTC Tripping	160°C
KTY Qty	1 no's
Fan	Single phase 230 V
Resolver	2 Pole, 1024 PPR
Connector	Yes (Fan, Resolver, Power Supply, KTY, PTC)
Weight	90 kg
IP	54
Mounting Type	Flange type, 4 mm Spigot
Color	BLACK RAL 9017
Ambient temp	45 °C
Shaft	Key less shaft, 80 mm Extension

• Torque Speed Curve:

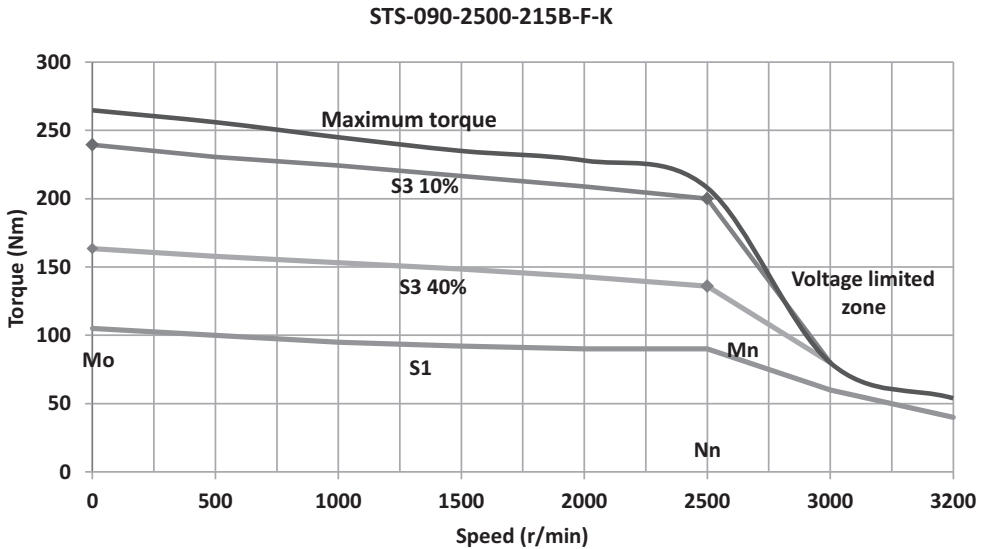

Notes:

1. **Mo** is standstill torque & **Mn** is the rated torque at rated speed **Nn**
2. S1 duty, S3 40% & S3 10% duty temp rise = 110 K
3. In peak condition that is max torque, motor can withstand for 15 to 20 sec, but also need to consider bear time of drive.

• **Basic requirements for safe & proper operation:**

7. Proper earthing at min. two points should be given to the motor.
8. Proper air ventilation needs to be provided to avoid overheating of motor.
9. All other standard procedures and practices to be followed.

5. PRE COMMISSIONING

5.1. Cooling fan

Please note the motor is fan cooled. Please maintain minimum distances between the motor's suction face and wall as well on the motor top as shown in below figure.

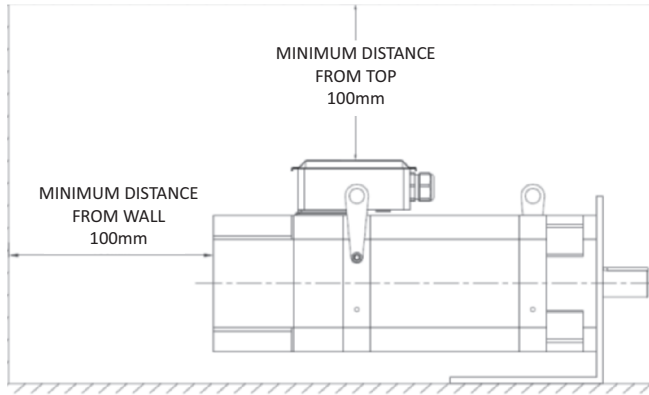

Figure 2

5.2. Shaft Load precautions

The servo motor shaft is not meant to take impact load. Please don't hammer the shaft while assembling or dismantling the coupling else it will damage the resolver or disturb the resolver setting.



**DO NOT HAMMER
ON MOTOR SHAFT**

Figure 3

5.3. Mounting

Servo motor is to be flange mounted as shown in the Figure 2

5.4. Environmental

- The ambient temperature must be within -10°C and $+45^{\circ}\text{C}$
- Maximum permissible humidity is 85%. (No moisture condensation)
- Do not operate the motor in an explosive atmosphere.
- Be aware of the protection class specified on the motor name plate.
- The deviation of the supply voltage fluctuation and rating does not exceed +7%.
- Transportation should be done with proper packing and as per BBL packing box.
- Storage should be in dust free and safe environmental conditions.
- Adequate ventilation and lighting arrangement are to be provided by the client.
- Any scrapping / Disposal has to be done as per the standard international practice.

6. ELECTRICAL CONNECTION

6.1. Earthing

For safety reason, it is very important that the motor should have properly earthing. Voltage between Earth and Neutral should be less than 3 Volts at standstill as well as during running. BBL servo motor unit contains two earthing points as shown in below images. Use the earthing bolts provided on the machine. Any one of these can be used for motor body protective earthing.

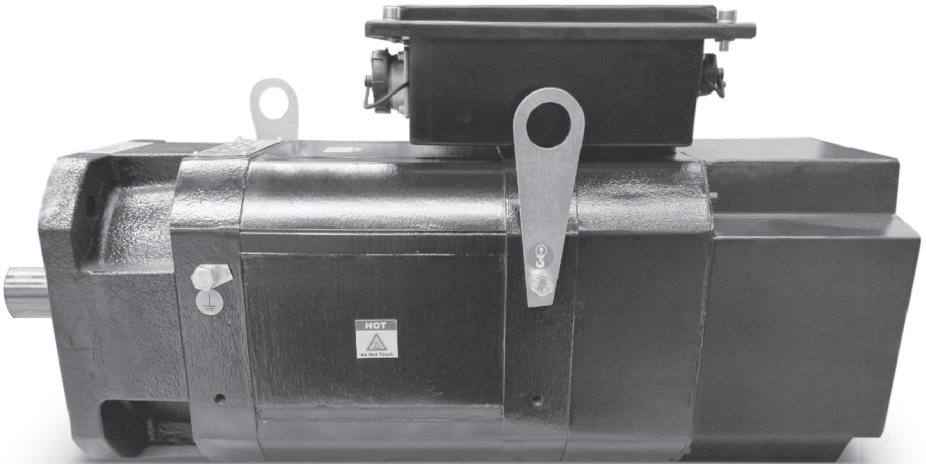

WARNING

Ensure that the shielding of the cable & 4th Core of the cable is connected to earth at motor as well as controller end.

6.2. Connection Diagram

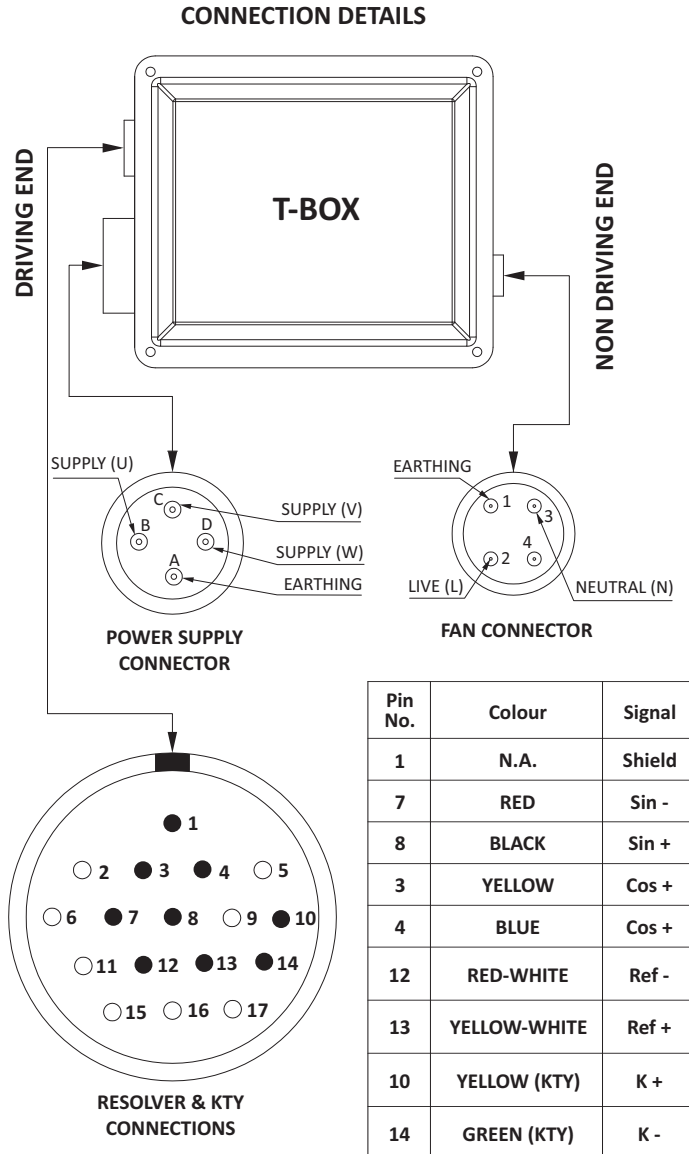

7. INSTALLATION

7.1. Before starting machine

Before starting the machine, go through the following checklist:

Sr. No	Check list	Recommended	YES	NO
1	Machine Mounting Bolts	Tighten		
2	Check Input Voltage to Drive	390 Volt A.C. to 415 Volt A.C.		
3	Check Machine Earthing during standstill & Running	< 3 Volt		
4	Winding Insulation Resistance	≥ 2 M-ohm		
5	Terminal Connection	Not loose (All Connections proper)		
6	Power Cable and Resolver Cable	Routed separately minimum 100mm clearance		
7	Earthing at 2 points to Gearless Machine Unit	Connected		
8	Shield of power cable is connected to Earth at Motor end, as well as at the Controller end.	Connected		
9	Thermistor / KTY connected with drive	Connected		
10	Fan connected to supply	Connected		

8.TROUBLESHOOTING

The proper maintenance of the motor requires adequately trained specialist personnel and specific devices and auxiliaries.

Fault	Causes	Remedy
Motor does not start	No input supply	Provide supply to VFD
	Motor terminal connection loose	Tight the terminal connection of VFD and Motor
	VFD setting wrong	Correct the VFD setting
	VFD defective	Replace VFD
	Motor is mechanically jam	Contact to BB
Drive trips after start	Wrong VFD selection	Change with higher capacity
	VFD setting faulty	Correct the VFD setting
	Short circuit in winding	Check winding resistance
	Short-circuiting to earth	Take off connection and check
	Short-circuiting to control	Exchange the faulty parts
Abnormal running noise or vibration	Resolver / Encoder cable routed with power cable	Maintain clearance between power cable and Resolver / Encoder cable.
	Resolver / Encoder defective	Change Resolver / Encoder
Motor taking more current	Resolver / Encoder not fixed properly	Fix Resolver / Encoder properly
	Resolver / Encoder cable connection wrong	Rectify Resolver / Encoder cable correctly
Excessive Temperature	Fan is not connected properly connected	Make fan connection as per diagram provided on Terminal box
	Fan Supply is off	Switch on supply
	Cooling fan is faulty	Replace the cooling fan
	VFD setting is wrong	Check VFD setting

9. MAINTENANCE

Ensure that during maintenance of the motor, the mains power supply and all other power sources are cut off.

- Ensure proper connections of power cable, fan cable & resolver cable.
- Check adequate screening and grounding for Encoder and motor power cable.
- Ensure that fixing screws are not loose and are properly tightened.
- Decouple the motor and rotate motor shaft?? with hand and see if there is noise heard from inside the motor. If noise is heard, get the motor serviced by BB authorized service personnel.
- Keep the surroundings of motor and pump free of water, dust and hazardous substances.
- Ensure the healthiness of motor temperature sensing devices (thermistor, KTY sensor) by regular resistance measurement and confirming the value as prescribed by the manufacturer.

9.1. Maintenance Interval

Following maintenance activities are recommending to be performed. Only qualified personnel are allowed to perform any maintenance work and follow the checklist given below:

Check list	Recommended	Duration
Motor		
Machine Mounting Bolts	No Loose	Three Months
Clean Machine Surface	No Dust	Three Months
Check Input Voltage to Drive	415 volt A.C.	Three Months
Check Machine Earthing	< 3 Volt	Three Months
Motor Vibration	< 0.50 mm/s	Three Months
Winding Insulation resistance	≥ 2 M-ohm @ 500VDC	Six Months
Load Current	Rated Current	Three Months
Bearing Noise	No Abnormal Noise	Three Months
Terminal Connection	No Loose	Three Months
Connection Cable	No Aging	Six Months

9.2 BB Servo motor: Dos & Don'ts

Sr. No.	Dos	Consequence of not implementing
1	Ensure proper earthing.	Improper earthing will cause unwanted noise signals.
2	Ensure proper alignment and coupling between the motor and the load.	Misalignment will generate unwanted axial forces that can stress and damage motor bearings.
3	Use suitable devices such as coupler, gear wheel or belt pulley to push on or pull off the coupling.	Use of wrong tools can result in bad coupling that can damage motor and load bearings.
4	For motor with key way, check the wear and tear in the key way. If gap found, then replace the key way.	Damaged key can lead to improper coupling between motor and load.
5	Ensure healthiness of power, fan, KTY/PTC and Encoder connections.	Bad connections can result in frequent drive tripping during operation.
6	Regularly clean the outer surface of the motor with blower or dry cloth to remove accumulated dust.	Dust can affect heat transfer and increase the motor temperature.
7	Ensure that the cooling fan blades are cleaned regularly by blowing air through the fan grill to remove accumulated dust.	Dust accumulated on fan blades can cause mechanical unbalance. This can result in overloading of fan winding and subsequent winding failure.
8	Ensure that the motor fan runs smoothly in the correct direction as per the direction arrow. Confirm with paper test that there is uniform air flow at all four corners.	Wrong direction of the fan will result in reduced cooling of the motor and cause motor failure due to overheating
9	If the motor is in OFF condition for longer period, conduct megger test before powering the motor.	It can result in short circuit and damage to motor parts.
#	<p>If sound heard from the motor while motor is running, then:</p> <ul style="list-style-type: none"> - Decouple the motor from the load and confirm again. - If sound is still heard, turn off power to motor and rotate motor shaft manually. - If motor shaft does not rotate smoothly, contact BB service centre for further guidance. 	Motor bearings can get damaged permanently and motor winding insulation can fail due to excessive temperature rise.

10. WARRANTY

Bharat Bijlee Ltd (BB) warrants that:

- Its Products and Components are free from any defects in design, material and workmanship for a period of 12 months from date of purchase.
- In the unlikely event of failure of the product or component(s) while under normal use within the above 12 month period, and if in the opinion of BB the defect is due to inherent defects in design or material or poor workmanship, BB will repair or replace at its sole discretion free of charge the defective component or product subject to the following terms and conditions:
- BB or its authorized repairer alone can inspect, service or repair the component Or Product Proof of purchase (original sales invoice and receipt) duly signed by BB officials or its authorized dealers must be provided with All warranty claims or requests

This warranty is void if any of the following circumstances occur:

- If the customer modifies any part of the product or component without notifying BB
- If unauthorized attachments are made to component/ product
- If the product is not installed in accordance with the user/installation manual and application guidelines of BB
- The Product/ component for which the claim is requested is tampered with
- The Product has been used in a way that does not confirm to the specifications for which it has been built as indicated in the User Manual
- The Identification plates are missing and therefore it is impossible to identify the product
- If any moneys remain outstanding and due to be paid by the customer on the total price of the product as per the sales invoice, in the books of account of BB

This warranty expressly excludes the following:



- Electrical components and windings
- Bearings
- Work surface damage/chipped, paint peel off due to wear and tear or misuse
- Cooling fan

All warranty claims must be communicated to BB in writing within 7 days from the date of occurrence of the problem.

- All defective material /component/ product(s) replaced will be the sole property of BB and shall be returned by the customer to BB.
- Under any circumstances, BB is not liable for any direct /indirect consequential loss or damage or expenses incurred by the buyer/user due to use of the product sold by BB.

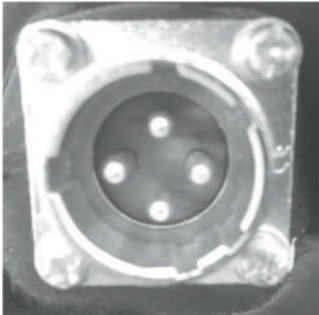

All disputes arising out of claims under this Warranty are to be first settled by mutual agreement, failing which should be referred to a Sole Arbitrator to be appointed by the Managing Director's of BBL and the award of such arbitrator shall be final and binding on parties. The Arbitration shall be conducted in accordance with the Arbitration & Conciliation Act, 1996 and any of its amendments/modifications thereon. The seat of Arbitration shall be Mumbai and only courts in Mumbai shall have exclusive jurisdiction notwithstanding that the product/ component may have been sold or delivered or installed elsewhere.

11. LIST OF ACCESSORIES

Sr. NO.	ITEM	PICTURE	QTY.
1.	COOLING FAN SR25 - EBM R2E190- A026-05		1
2.	CAPACITOR (FOR COOLING FAN)		1
3.	FAN CONNECTOR		1

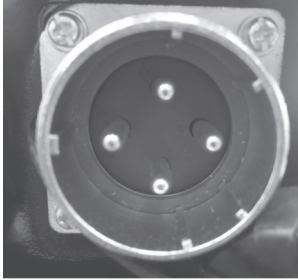
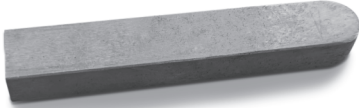
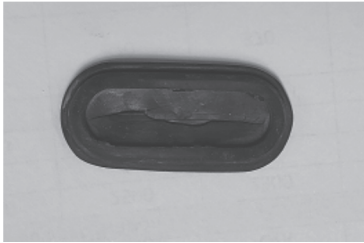
Sr. NO.	ITEM	PICTURE	QTY.
7.	OIL SEAL 68X100X10 R010680807 SR25	 A black, circular oil seal with a raised outer lip and a recessed inner lip, shown against a light background.	1
8.	LIFTING PLATE	 Two identical metal lifting plates, each with a circular hole on the left and two small circular holes on the right, shown against a light background.	2
9.	INLET RING	 A black, circular inlet ring with a raised outer lip and a recessed inner lip, shown against a light background.	1

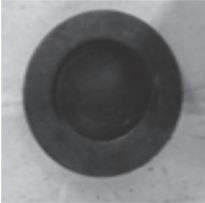
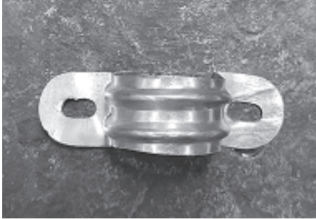
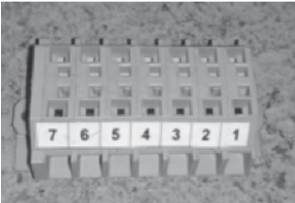
Sr. NO.	ITEM	PICTURE	QTY.
7.	POWER CONNECTOR FOR 50 NM & 70 Nm		1
8.	KEY FOR COUPLING (12X8X70) (SR25)		1
9.	RUBBER GROMMET GS 150-90X5		1

Sr. NO.	ITEM	PICTURE	QTY.
10.	RUBBER GROMET DIA. 26X2 THK.		1
11.	CAPACITOR SADDLE 1"		2
12.	TERMINAL BLOCK		1
13.	POWER CONNECTOR FOR 90NM		1

11. CERTIFICATION



CERTIFICATE

QA-AC-5010/20

QA TECHNIC – ATTESTATION OF CONFORMITY

2006/42/EC MACHINERY DIRECTIVE
2014/35/EU LOW VOLTAGE DIRECTIVE
2014/30/EU ELECTROMAGNETIC COMPATIBILITY DIRECTIVE

BHARAT BIJLEE LTD
Electric Mansion, 6th Floor, Appasaheb Marathe Marg,
Prabhadevi, Mumbai 400025.

Manufacturing Address	: Magnet Technology Machines Division No2 , MIDC, Thane-Belapur Road, Airoli Navi Mumbai 400708.									
Product Name	: Permanent Magnet Synchronous Motor									
Product Name (s) / Model (s)	: <table border="1" style="margin-left: 20px; border-collapse: collapse;"> <thead> <tr> <th style="font-size: 8px;">Model</th> <th style="font-size: 8px;">Rating kW</th> <th style="font-size: 8px;">Speed (rpm)</th> </tr> </thead> <tbody> <tr> <td style="font-size: 8px;">Green Star</td> <td style="font-size: 8px;">0.5 to 100</td> <td style="font-size: 8px;">up to 600</td> </tr> <tr> <td style="font-size: 8px;">Synchrotrorg</td> <td style="font-size: 8px;">0.5 to 200</td> <td style="font-size: 8px;">up to 3600</td> </tr> </tbody> </table>	Model	Rating kW	Speed (rpm)	Green Star	0.5 to 100	up to 600	Synchrotrorg	0.5 to 200	up to 3600
Model	Rating kW	Speed (rpm)								
Green Star	0.5 to 100	up to 600								
Synchrotrorg	0.5 to 200	up to 3600								
Product Commercial Brand	:  Bharat Bijlee									
Applicable EC Directive (s)	: MACHINERY DIRECTIVE (2006/42/EC) LOW VOLTAGE DIRECTIVE (2014/35/EU) EMC DIRECTIVE (2014/30/EU)									
Applicable Harmonized Standard(s)/	: IEC 60034-1 :2017									
Test Report(s) and Date(s)	: SWEN KONFORMITY SWEN/20-21/181-01; 23/11/2020									

The Present certificate is valid just for the analysed product design. The certificate shall lose its validity in case of any changes in the product.

The CE mark as shown below can be used, under the responsibility of the manufacturer or the importer, after completion of an EC Declaration of Conformity and compliance with all relevant EC Directives.

<p style="font-size: 10px;">Certificate Issue Date : 30.11.2020 <i>Sertifika Düzenlenme Tarihi</i></p> <p style="font-size: 10px;">Certificate Expiry Date : 30.11.2025 <i>Sertifikasyon Bitiş Tarihi</i></p>		<p style="font-size: 10px;">Certificate Validity Date : 30.11.2021 <i>Sertifika Geçerlilik Tarihi</i></p> <p style="font-size: 10px;">Re-Assessment Period : 5 years <i>Belgelendirme Periyodu</i></p>
---	---	--

ALBERK QA INTERNATIONAL
TECHNICAL CONTROL AND
CERTIFICATION CORP.
www.qatechnic.com
ce@qatechnic.com

Begüm ADAKAN
Overseas Operation Manager





KARANDIKAR LABORATORIES PVT. LTD. BOISAR

Format: F#07 b.2 Rev 03

TYPE TEST REPORT

IS/IEC 60034-5:2000

Degrees of Protection Provided by Enclosures (IP Code)

Report No. : KLPL/BTG/22/10-93
 ULR No. : TC63112200000532F
 Discipline : Electrical Discipline
 Group/Category : Environmental Test Facility
 Sub-category : Ingress protection test
 Date of issue..... : **16.11.2022**
 No. of pages : 07 PAGES + Annexure



Compiled by (+ signature)..... : Rohit Patil 
 Designation: Testing Engineer
 Approved by (+ signature)..... : Atul Marathe 
 Designation: Technical Manager

Item Received On : 29.10.2022 In Good Condition

Test Completion Date : 12.11.2022

Client

Name : M/s. Bharat Bijlee Limited
 : No.2, MIDC, Thane-Belapur Road, Airoli, Navi Mumbai-400708.

Test Specification

Standard : IS/IEC 60034-5:2000
 Specified IP-Code..... : IP65

Equipment Under Test

Type of Test Object : Servo Motor: 18.32.KW, 70Nm, 39.00A, 370V, 2500 RPM
 Model/Type : STS-090-2500-215B-F-O
 Serial No. : G2200429
 Manufacturer : M/s. Bharat Bijlee Limited

Annexure :-

Drawing No. : 3ES-02-2258, Rev.No.00, Dated:02.03.2022, (01 Page)
 4ES-02-2115, Rev.No.00, Dated:25.03.2022, (01 Page)
 4ES-02-2439, Rev.No.00, Dated:14.10.2020, (01 Page)

NOTE: 1) This refers only to the particular item(s) submitted for testing.
 2) If necessary, this report shall be reproduced ONLY in full.



Head Office: B-101, Ansa Industrial Estate, Saki Vihar Road, Saki Naka, Andheri (E) Mumbai-400072 INDIA Ph: (022) 28471395
 Laboratory: G2#142, Betegaon, Boisar Chillar Road, Opp. Union Park, Boisar (E), Tal-Palghar, Dist Palghar-401501 INDIA
 Phone (022525) 284681/931 Website: www.karandikarlab.com

Email: sales@karandikarlab.com

Website: www.karandikarlab.com

ALL INDIA SERVICE NETWORK

- Regional Offices
- 🔥 Works
- ✂ Service Centre: Drives
- ✂ Service Centre: Servo Motors



BB ServiceLINE[®]
Customer Service Helpdesk for Industrial Systems

+91 22 - 2763 7290 | serviceline@bharatbijlee.com



Bharat Bijlee Drives & Automation

Mobile App for Troubleshooting and Maintenance of Drives & Servo Motors
Download for free from Google Play Store



REGISTERED OFFICE

Electric Mansion, 6th Floor,
Appasaheb Marathe Marg,
Prabhadevi, Mumbai 400 025
T: +91 22 2430 6237 / 6375
E: info@bharatbijlee.com
CIN: L31300MH1946PLC005017

WORKS

No. 2, MIDC Thane-Belapur Road, Airoli,
Navi Mumbai 400 708
T: +91 22 2763 7200 / +91 22 2760 0401
E: drivesales@bharatbijlee.com

www.bharatbijlee.com

All product designations may be trademarks or product names of Bharat Bijlee Ltd, or of its partner or supplier companies, and whose use by third parties for their own purposes could violate the rights of the owners.

Product improvement is a continuous process and technical information herein is subject to change. Please contact our nearest sales office for the latest information.