

# BBVERT **BL51**



---

**INSTRUCTION MANUAL**

---

## Table of Contents

<b>Chapter 0 Preface</b>	<b>2</b>
0.1 Preface .....	2
<b>Chapter 1 Safety Precautions</b>	<b>3</b>
1.1 Before Power Up .....	3
1.2 During Power Up .....	4
1.3 Before Operation .....	4
1.4 During Operation .....	4
1.5 Inverter Disposal .....	5
<b>Chapter 2 Part No. Definition</b>	<b>6</b>
2.1 Model Part Number .....	6
2.2 Standard Product Specification.....	7
<b>Chapter 3 Environment and Installation</b>	<b>8</b>
3.1 Environment .....	8
3.1.1 Wiring and EMC Guidelines.....	9
3.1.2 Considerations for Peripheral Equipment .....	10
3.2 Specifications .....	11
3.2.1 Product Specifications .....	11
3.2.2 General Specifications .....	12
3.3 Standard Wiring .....	14
3.3.1 200 V Single Phase PNP Input .....	14
3.3.2 400 V Three Phase PNP Input .....	15
3.3.3 400 V Single Phase PNP/NPN Selectable .....	16
3.3.4 Single/Multi-Pump Dedicated Wiring Diagram (When 14-00=1) .....	17
3.4 Terminal Description .....	19
3.4.1 Description of Main Circuit Terminals .....	19
3.4.2 Control Circuit Terminal Description .....	20
3.5 Outline Dimensions .....	22
<b>Chapter 4 Software Index</b>	<b>27</b>
4.1 Keypad Description .....	27
4.1.1 Operator Panel Function .....	27
4.2 Programmable Parameter Groups .....	28
<b>Chapter 5 Troubleshooting and Maintenance</b>	<b>46</b>
5.1 Error Display and Corrective Action .....	46
5.1.1 Manual Reset and Auto Reset .....	46
5.1.2 Keypad Operation Error Instruction .....	49
5.1.3 Special Conditions .....	50
5.2 General Troubleshooting .....	51
<b>Chapter 6 Peripheral Components</b>	<b>52</b>
6.1 Reactor Specifications .....	52
6.2 Electromagnetic Contactor and No Fuse Circuit Breaker .....	52
6.3 Fuse Specification .....	52
6.4 Fuse Specification (UL Model Recommendation) .....	53
6.5 Braking Resistor .....	53

# Chapter 0 Preface

## 0.1 Preface

To extend the performance of the product and ensure personnel safety, please read this manual thoroughly before using the inverter. Should there be any problem in using the product that cannot be solved with the information provided in the manual, contact our technical or sales representative who will be willing to help you.

### ※Precautions

The inverter is an electrical product. For your safety, there are symbols such as “Danger”, “Caution” in this manual as a reminder to pay attention to safety instructions on handling, installing, operating, and checking the inverter. Be sure to follow the instructions for highest safety.

#### **Danger**

Indicates a potential hazard that could cause death or serious personal injury if misused.

#### **Caution**

Indicates that the inverter or the mechanical system might be damaged if misused.

#### **Danger**

- Risk of electric shock. The DC link capacitors remain charged for five minutes after power has been removed. It is not permissible to open the equipment until 5 minutes after the power has been removed.
- Do not make any connections when the inverter is powered on. Do not check parts and signals on circuit boards during the inverter operation.
- Do not disassemble the inverter or modify any internal wires, circuits, or parts.
- Ensure that the Inverter Ground terminal is connected correctly.

#### **Caution**

- Do not perform a voltage test on parts inside the inverter. High voltage can destroy the semiconductor components.
- Do not connect T1, T2, and T3 terminals of the inverter to any AC input power supply.
- CMOS ICs on the inverter’s main board are susceptible to static electricity. Do not touch the main circuit board.

# Chapter 1 Safety Precautions

## 1.1 Before Power Up

### Danger

- Make sure the main circuit connections are correct. Single phase L1(L),L3(N), and Three phase L1(L),L2,L3(N); 400V : L1,L2,L3 are power-input terminals and must not be mistaken for T1,T2 and T3. Otherwise, inverter damage can result.

### Caution

- The line voltage applied must comply with the inverter's specified input voltage.(See the nameplate)
- To avoid the front cover from disengaging, or other damage do not carry the inverter by its covers. Support the drive by the heat sink when transporting. Improper handling can damage the inverter or injure personnel and should be avoided.
- To avoid the risk of fire, do not install the inverter on a flammable object. Install on nonflammable objects such as metal.
- If several inverters are placed in the same control panel, provide heat removal means to maintain the temperature below 50 degree C to avoid overheats or fire.
- When disconnecting the remote keypad, turn the power off first to avoid any damage to the keypad or the inverter.
- Installation limitation, -10~50°C (cooling fan inside model), -10~40°C (without cooling fan inside model)

### Warning

- This product is sold subject to EN 61800-3 and EN 61800-5-1. In a domestic environment this product may cause radio interference in which case the user may be required to apply corrective measures.

### Caution

- Work on the device/system by unqualified personnel or failure to comply with warnings can result in severe personal injury or serious damage to material. Only suitably qualified personnel trained in the setup, installation, commissioning and operation of the product should carry out work on the device/system.
- Only permanently-wired input power connections are allowed.

## 1.2 During Power Up

### Danger

- When the momentary power loss is longer than 2 seconds, the inverter will not have sufficient stored power for its control circuit. Therefore, when the power is re-applied, the run operation of the inverter will be based on the setup of following parameters:

- Run parameters. 00-02 or 00-03.
- Direct run on power up. Parameter. 07-04 and the status of external run switch,

**Note-** The start operation will be regardless of the settings for parameters 07-00/07-01/07-02.

### Danger. Direct run on power up.

If direct run on power up is enabled and inverter is set to external run with the run FWD/REV switch closed then the inverter will restart.

### Danger

Prior to use, ensure that all risks and safety implications are considered.

- When the momentary power loss ride through is selected and the power loss is short, the inverter will have sufficient stored power for its control circuits to function, therefore, when the power is resumed the inverter will automatically restart depending on the setup of parameters 07-00 & 07-01.

## 1.3 Before Operation

### Caution

- Make sure the model and inverter capacity are the same as that set in parameter 13-00.

**Note:** On power up the supply voltage set in parameter 01-01 will flash on display for 2 seconds.

## 1.4 During Operation

### Danger

- Do not connect or disconnect the motor during operation. Otherwise, It may cause the inverter to trip or damage the unit.

### Danger

- To avoid electric shock, do not take the front cover off while power is on.
- The motor will restart automatically after stop when auto-restart function is enabled. In this case, care must be taken while working around the drive and associated equipment.
- The operation of the stop switch is different than that of the emergency stop switch. The stop switch has to be activated to be effective. Emergency stop has to be de-activated to become effective.

 **Caution**

- Do not touch heat radiating components such as heat sinks and brake resistors.
- The inverter can drive the motor from low speed to high speed. Verify the allowable speed ranges of the motor and the associated machinery.
- Note the settings related to the braking unit.
- Risk of electric shock. The DC link capacitors remain charged for five minutes after power has been removed. It is not permissible to open the equipment until 5 minutes after the power has been removed.

 **Caution**

- The Inverter should be used in environments with temperature range from (14-104°F) or (-10 to 40°C) and relative humidity of 95%.

Note: models with fan: -10~50°C, models without fan: -10~40°C

 **Danger**

- Make sure that the power is switched off before disassembling or checking any components.

## 1.5 Inverter Disposal

 **Caution**

Please dispose of this unit with care as an industrial waste and according to your required local regulations.

- The capacitors of inverter main circuit and printed circuit board are considered as hazardous waste and must not be burnt.
- The Plastic enclosure and parts of the inverter such as the cover board will release harmful gases if burnt.
- Packing material to be disposed as per applicable central/state/local regulations.



Equipment containing electrical components may not be disposed of together with domestic waste. It must be separately collected with electrical and electronic waste according to local and currently valid legislation

# Chapter 2 Part Number Definition

## 2.1 Model part number

# BL51 – 20XXX – H1F - P

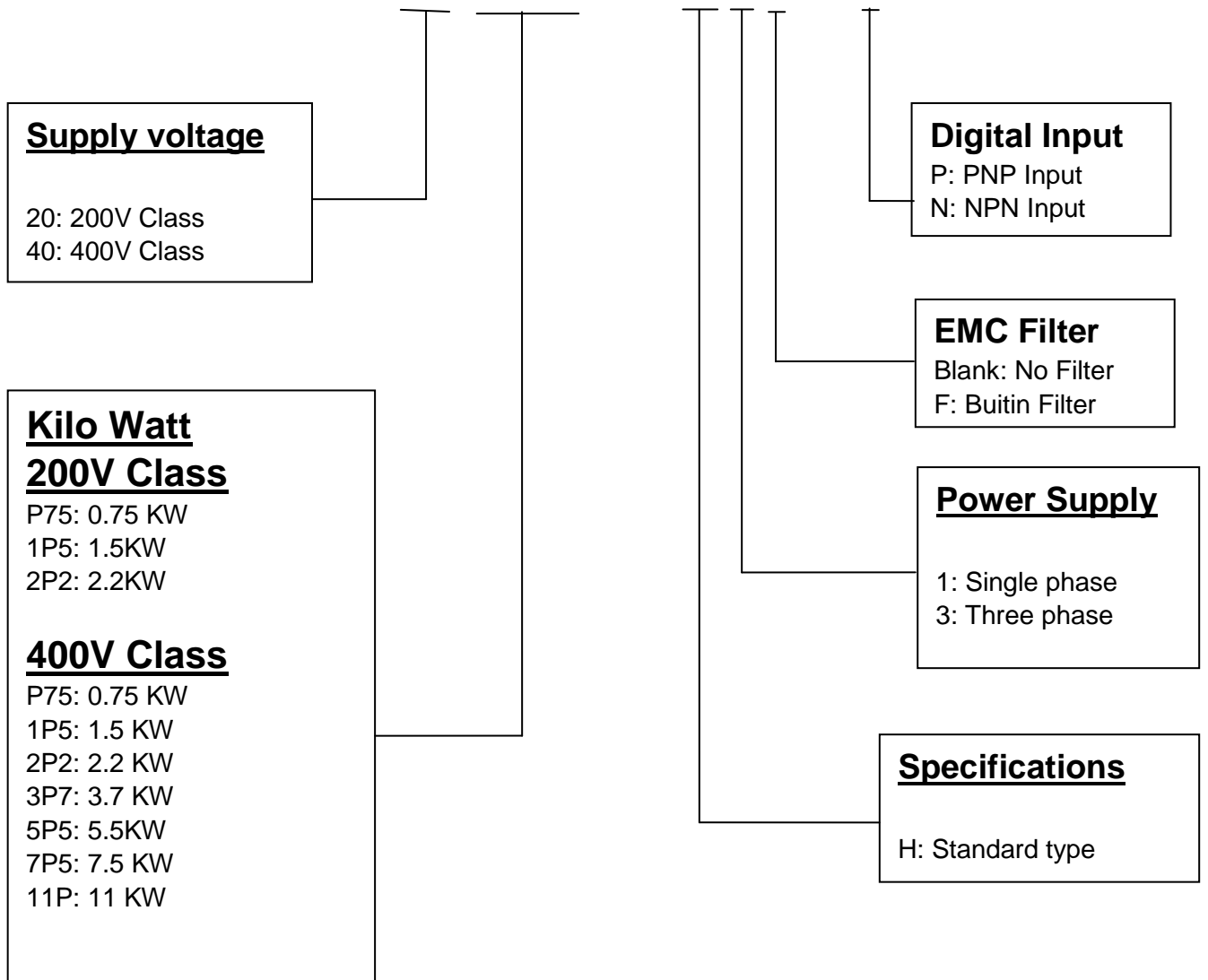

## 2.2 Standard product specification

Model	Supply voltage (Vac)	Frequency (Hz)	(KW)	Filter		Series		Frame Size
				BuiltIn	None	PNP	NPN	
BL51-20P75-H1-P	1 ph, 200 - 240V +10% / -15%	50/60 Hz	0.75		⊙	⊙		1
BL51-201P5-H1-P			1.5		⊙	⊙		2
BL51-202P2-H1-P			2.2		⊙	⊙		2
BL51-20P75-H1F-P			0.75	⊙		⊙		1
BL51-201P5-H1F-P			1.5	⊙		⊙		2
BL51-202P2-H1F-P			2.2	⊙		⊙		2
BL51-40P75-H3-P	3 ph, 380 - 480V +10% / -15%		0.75		⊙	⊙		2
BL51-401P5-H3-P			1.5		⊙	⊙		2
BL51-402P2-H3-P			2.2		⊙	⊙		2
BL51-403P7-H3-P			3.7		⊙	⊙	⊙	3
BL51-405P5-H3-P			5.5		⊙	⊙	⊙	3
BL51-407P5-H3-P			7.5		⊙	⊙	⊙	4
BL51-4011P-H3-P		11		⊙	⊙	⊙	4	
BL51-40P75-H3F-P		0.75	⊙		⊙		2	
BL51-401P5-H3F-P		1.5	⊙		⊙		2	
BL51-402P2-H3F-P		2.2	⊙		⊙		2	
BL51-403P7-H3F-P		3.7	⊙		⊙	⊙	3	
BL51-405P5-H3F-P		5.5	⊙		⊙	⊙	3	
BL51-407P5-H3F-P		7.5	⊙		⊙	⊙	4	
BL51-4011P-H3F-P		11	⊙		⊙	⊙	4	

Short circuit capacity is below 5000A/120V or 5000A/240V or 5000A/480V, for 100~120V models is 120V; 200~240V models is 240V, 380~480V models is 480V

# Chapter 3 Environment & Installation

## 3.1 Environment

Installation environment has a direct effect on the correct operation and the life expectancy of the inverter, Install the inverter in an environment complying with the following conditions:

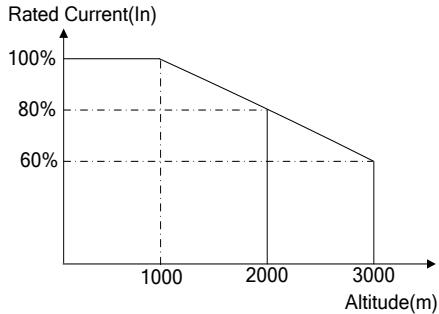
Protection											
Protection class	IP20 Open Type										
Suitable environment											
Operating temperature	-10~40°C(-10~50°C with fan) (non-freezing) If several inverters are installed in the same control panel, ensure adequate spacing and provide the necessary cooling and ventilation for successful operation.										
Storage temperature	-20~60°C										
Relative Humidity	Max 95% (without condensation)										
Altitude	<p>Altitude : Below 1000m (3281ft)</p> <p>It is required to reduce 2% of inverter rated current at each additional 100m. The maximum altitude is 3000m</p>  <table border="1"> <caption>Rated Current vs Altitude</caption> <thead> <tr> <th>Altitude (m)</th> <th>Rated Current (In)</th> </tr> </thead> <tbody> <tr> <td>0</td> <td>100%</td> </tr> <tr> <td>1000</td> <td>100%</td> </tr> <tr> <td>2000</td> <td>80%</td> </tr> <tr> <td>3000</td> <td>60%</td> </tr> </tbody> </table>	Altitude (m)	Rated Current (In)	0	100%	1000	100%	2000	80%	3000	60%
Altitude (m)	Rated Current (In)										
0	100%										
1000	100%										
2000	80%										
3000	60%										
Vibration	<p>Frequency: 10Hz - 150Hz - 10Hz</p> <p>Amplitude(0.3mm): 10Hz ≤ f ≤ 57Hz</p> <p>Acceleration(2G): 57Hz ≤ f ≤ 150Hz</p> <p>(According to IEC60068-2-6 standard)</p>										

### Installation site

Install in an environment that will not have an adverse effect on the operation of the unit and ensure that there is no exposure to areas such as that listed below:-

- Direct sunlight, Rain or moisture
- Oil mist and salt
- Dust, lint fibers, small metal filings and corrosive liquid and gas
- Electromagnetic interference from sources such as welding equipment
- Radioactive and flammable materials
- Excessive vibration from machines such as stamping, punching machines
- Add vibration-proof pads if necessary

### 3.1.1 Wiring and EMC guidelines

For effective interference suppression, do not route power and control cables in the same conduit or trunking.

To prevent radiated noise, motor cable should be put in a metal conduit. Alternatively an armored or shielded type motor cable should be used.

For effective suppression of noise emissions the cable armor or shield must be grounded at both ends to the motor and the inverter ground. These connections should be as short as possible.

Motor cable and signal lines of other control equipment should be at the least 30 cm apart.

BL51 has a built in Class "A" EMC filter to first Environment Restricted. (Category C2).

For some installations such as residential,(Category C1) an optional external Class "B" type filter will be necessary. Please consult your local supplier.

#### Typical Wiring

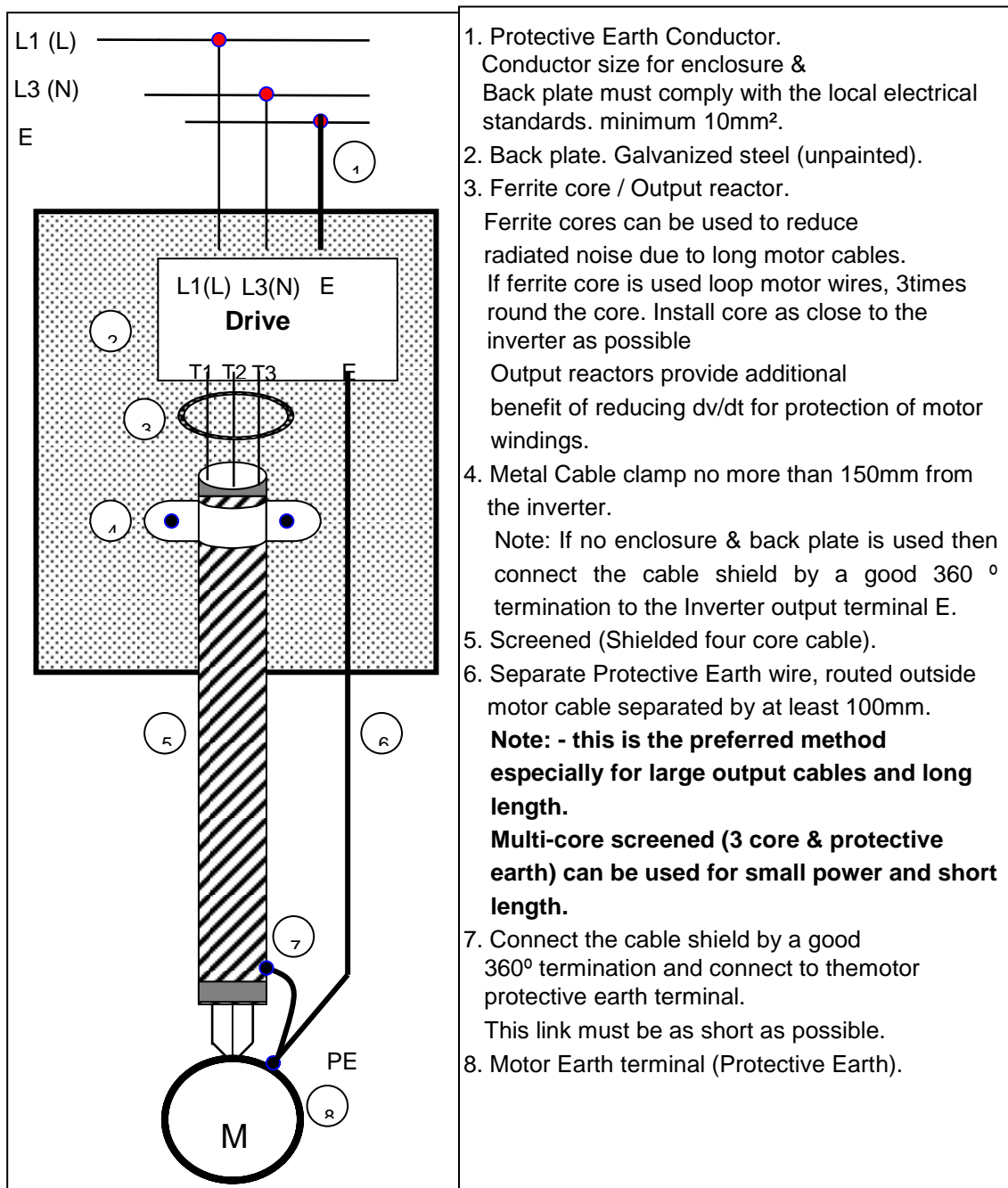

### 3.1.2 Considerations for peripheral equipment

	<p>Power</p>	<p>Ensure that the supply voltage is correct. A molded-case circuit breaker or fused disconnect must be installed between the AC source and the inverter</p>
<p>Circuit Breaker &amp;RCD</p>	<p>Use a molded-case circuit breaker that conforms to the rated voltage and current of the inverter. Do not use the circuit breaker as the run/stop switch for the inverter. Residual Current Circuit Breaker(RCD) Current setting should be 200mA or above and the operating time at 0.1 second or longer to prevent malfunctions.</p>	
<p>Magnetic contactor</p>	<p>Normally a magnetic contactor is not needed. A contactor can be used to perform functions such as external control and auto restart after power failure. Do not use the magnetic contactor as the run/stop switch for the inverter.</p>	
<p>AC reactor for power quality improvement</p>	<p>When a 200V/400V inverter with rating below 15KW is connected to a high capacity power source (600kVA or above) then an AC reactor can be connected for power factor improvement and reducing harmonics.</p>	
<p>Input noise filter</p>	<p>BL51 inverter has a built-in filter to Class "A" first Environment. (CategoryC2) To satisfy the required EMC regulations for your specific application you may require an additional EMC filter.</p>	
<p>Inverter</p>	<p>Connect the single phase power to Terminals, L1(L) &amp; L3(N) and three phase power to Terminals : ( 400V : L1,L2,L3). Warning! Connecting the terminals T1, T2, and T3 to AC input power will damage the inverter. Output terminals T1, T2, and T3 are connected to U, V, and W terminals of the motor. To reverse the motor rotation direction just swap any two wires at terminals T1, T2, and T3. Ground the Inverter and motor correctly.Ground Resistance for 200V power&lt;100 Ohms.</p>	
<p>Motor</p>	<p>Three-phase induction motor. Voltage drop on motor due to long cable can be calculated. Volts drop should be &lt; 10%. Phase-to-phase voltage drop (V) = <math>\sqrt{3} \times \text{resistance of wire } (\Omega/\text{km}) \times \text{length of line (m)} \times \text{current} \times 10^{-3}</math></p>	

## 3.2 Specifications

### 3.2.1 Product Specifications

#### 200V Class: Single phase.

<b>Model : BL51-20XXX-H1X-P</b>	<b>20P75</b>	<b>201P5</b>	<b>202P2</b>
Power (KW)	<b>0.75</b>	<b>1.5</b>	<b>2.2</b>
Suitable motor capacity (KW)	<b>0.75</b>	<b>1.5</b>	<b>2.2</b>
Rated output current (A)	<b>4.3</b>	<b>7.5</b>	<b>10.5</b>
Rated capacity (KVA)	<b>1.65</b>	<b>2.90</b>	<b>4.00</b>
Input voltage range(V)	Single Phase : <b>200~240V(+10%-15%),50/60HZ</b>		
Output voltage range(V)	Three phase <b>0~240V</b>		
Input current (A)	<b>11</b>	<b>15.5</b>	<b>21</b>
weight(KG)	<b>0.9</b>	<b>1.4</b>	<b>1.4</b>
weight with filter(KG)	<b>1.0</b>	<b>1.5</b>	<b>1.5</b>
Allowable momentary power loss time (S)	<b>1.0</b>	<b>2.0</b>	<b>2.0</b>
Enclosure	<b>IP20</b>		

#### 400V Class: Three phase.

<b>Model : BL51-40XXX-H3X-P</b>	<b>40P75</b>	<b>401P5</b>	<b>402P2</b>
Power (KW)	<b>0.75</b>	<b>1.5</b>	<b>2.2</b>
Suitable motor capacity (KW)	<b>0.75</b>	<b>1.5</b>	<b>2.2</b>
Rated output current (A)	<b>2.3</b>	<b>3.8</b>	<b>5.2</b>
Rated capacity (KVA)	<b>1.7</b>	<b>2.9</b>	<b>4.0</b>
Input voltage range(V)	Three Phase : <b>380~480V (+10%-15%),50/60HZ</b>		
Output voltage range(V)	Three phase <b>0~480V</b>		
Input current (A)	<b>4.2</b>	<b>5.6</b>	<b>7.3</b>
weight(KG)	<b>1.4</b>	<b>1.4</b>	<b>1.4</b>
weight with filter(KG)	<b>1.5</b>	<b>1.5</b>	<b>1.5</b>
Allowable momentary power loss time (S)	<b>2.0</b>	<b>2.0</b>	<b>2.0</b>
Enclosure	<b>IP20</b>		

<b>Model :BL51-40XXX-H3X-P</b>	<b>403P7</b>	<b>405P5</b>	<b>407P5</b>	<b>4011P</b>
Power (KW)	<b>3.7</b>	<b>5.5</b>	<b>7.5</b>	<b>11</b>
Suitable motor capacity (KW)	<b>3.7</b>	<b>5.5</b>	<b>7.5</b>	<b>11</b>
Rated output current (A)	<b>9.2</b>	<b>13.0</b>	<b>17.5</b>	<b>24</b>
Rated capacity (KVA)	<b>7.01</b>	<b>9.91</b>	<b>13.34</b>	<b>18.29</b>
Input voltage range(V)	Three Phase: <b>380~480V (+10%-15%),50/60HZ</b>			
Output voltage range(V)	Three Phase <b>0~480V</b>			
Input current (A)	<b>10.1</b>	<b>14.3</b>	<b>19.3</b>	<b>26.4</b>
weight(KG)	<b>2.5</b>	<b>2.5</b>	<b>6.3</b>	<b>6.3</b>
weight with filter(KG)	<b>2.7</b>	<b>2.7</b>	<b>6.3</b>	<b>6.3</b>
Allowable momentary power loss time (S)	<b>2</b>	<b>2</b>	<b>2</b>	<b>2</b>
Enclosure	<b>IP20</b>			

### 3.2.2 General Specifications

Item		BL51
<b>Control Mode</b>		V/F Control +SLV control
<b>Frequency</b>	Range	0.01~599.00Hz
	Speed accuracy (100% torque)	V/F: 3% SLV: 1%
	Starting Torque	V/F: 3Hz / 100% SLV: 3Hz / 150%
	Setting resolution	Digital input : 0.01Hz Analog input : 0.015Hz/60Hz
	Frequency Setting	Keypad : Set directly with ▲ ▼ keys or the VR (Potentiometer) on the keypad External Input Terminals: AVI(0/2~10V), ACI(0/4~20mA)input Multifunction input up/down function(Group3) Setting frequency by Communication method. <a href="#">Remote control: Set directly with ▲ ▼ keys of remote keypad</a>
Frequency limit	Lower and upper frequency limits, 3 -skip frequency settings.	
<b>Run</b>	Operation set	Keypad run, stop button External terminals: Multi- operation-mode 2 / 3 wire selection Jog operation Run signal by communication method. <a href="#">Remote control: Set directly with run, stop button of remote keypad</a>
<b>Main Controls</b>	V / F curve setting	6 fixed curve and one customized curve
	Carrier frequency	1~16kHz(default 5kHz)
	Acceleration and deceleration control	2 nos. Acc / Dec time parameters. 4 nos. S curve parameters.
	Multifunction input	19 functions (refer to description on group3), 5 point Frame1/2 : NPN&PNP by separate models Frame 3/4 : NPN&PNP switchable
	Multifunction output	16 functions (refer to description on group3), 1 point
	Multifunction analog input	AVI (0/2 - 10V), ACI (0/4 – 20mA) input, 2 point. (refer to description on group 4)
	Multifunction analog output	5 functions (refer to description on group4) 1 point (0~10V)
	Main features	Overload Detection, 8 preset speeds, Auto-run, Acc/Dec Switch (2 Stages), Main/Alt run Command select, Main/Alt Frequency Command select, PID control, torque boost, V/F start Frequency ,Fault reset. <a href="#">Constant Pressure and Multi-Pump Parallel Connection Function.</a>
<b>Display</b>	LED	Display: parameter/parameter value/frequency/line speed/DC voltage/output voltage/output current/PID feedback/input and output terminal status/Heat sink temperature/Program Version/Fault Log.
	LED Status Indicator	For run/stop/forward and reverse.
<b>Protective Functions</b>	Overload Protection	Integrated motor and Inverter overload protection. (150%/60sec)
	Over voltage	200V : Over 410V, 400V : Over 820V
	Under voltage	200V : Under 190V, 400V : Under 380V

	Momentary Power Loss Restart	Inverter auto-restart after a momentary power loss.
	Stall Prevention	Stall prevention for Acceleration/ Deceleration and continuous Run.
	Short-circuit output terminal	Electronic Circuit Protection
	Grounding Fault	Electronic Circuit Protection
	Additional protective functions	heat sink over temperature protection, Auto carrier frequency reduction with temperature rise, fault output, reverse prohibit, Number of auto restart attempts, Parameter lock, over voltage protection(OVP), motor PTC over-temperature protection
<b>International Certification</b>		CE
<b>Communication</b>		RS485 (Modbus) built in, with one to one or one to many control. Built-in BacNet communication. Profibus, DeviceNet, CANopen, TCP/IP by gateways. <a href="#">Built-in Constant Pressure and Multi-Pump Parallel Connection Function.</a>
<b>Environment</b>	Operating temperature	-10~50°C(with fan), -10~40°C(without fan)
	Storage temperature	-20~60°C
	Humidity	Under 95%RH(no condensation)
	Vibration	Frequency: 10Hz - 150Hz - 10Hz Amplitude(0.3mm): 10Hz ≤ f ≤ 57Hz Acceleration(2G): 57Hz ≤ f ≤ 150Hz (According to IEC60068-2-6 standard)
	EMC Compliance	EN61800-3, First Environment (Use of the optional grounding kit is recommended to achieve compliance.).
	LVD Compliance	EN 61800-5-1
	Electrical Safety	UL508C
	Protection level	IP20

### 3.3 Standard wiring

#### 3.3.1 200V single phase: BL51-20P75~202P2

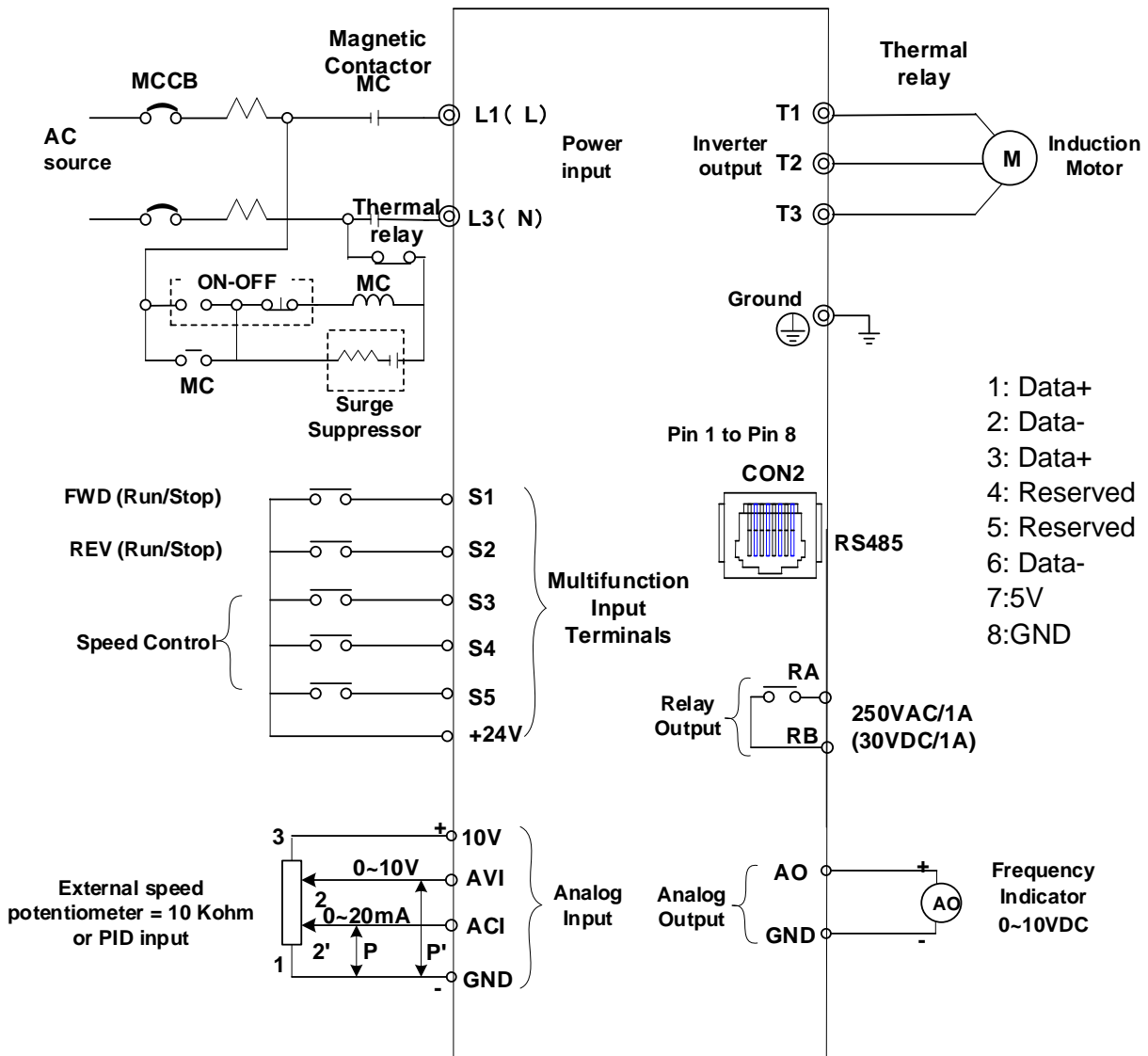

Model 200V:

- BL51-20P75-H1X-P
- BL51-201P5-H1X-P
- BL51-202P2-H1X-P

### 3.3.2 400V three phase: BL51-40P75~402P2

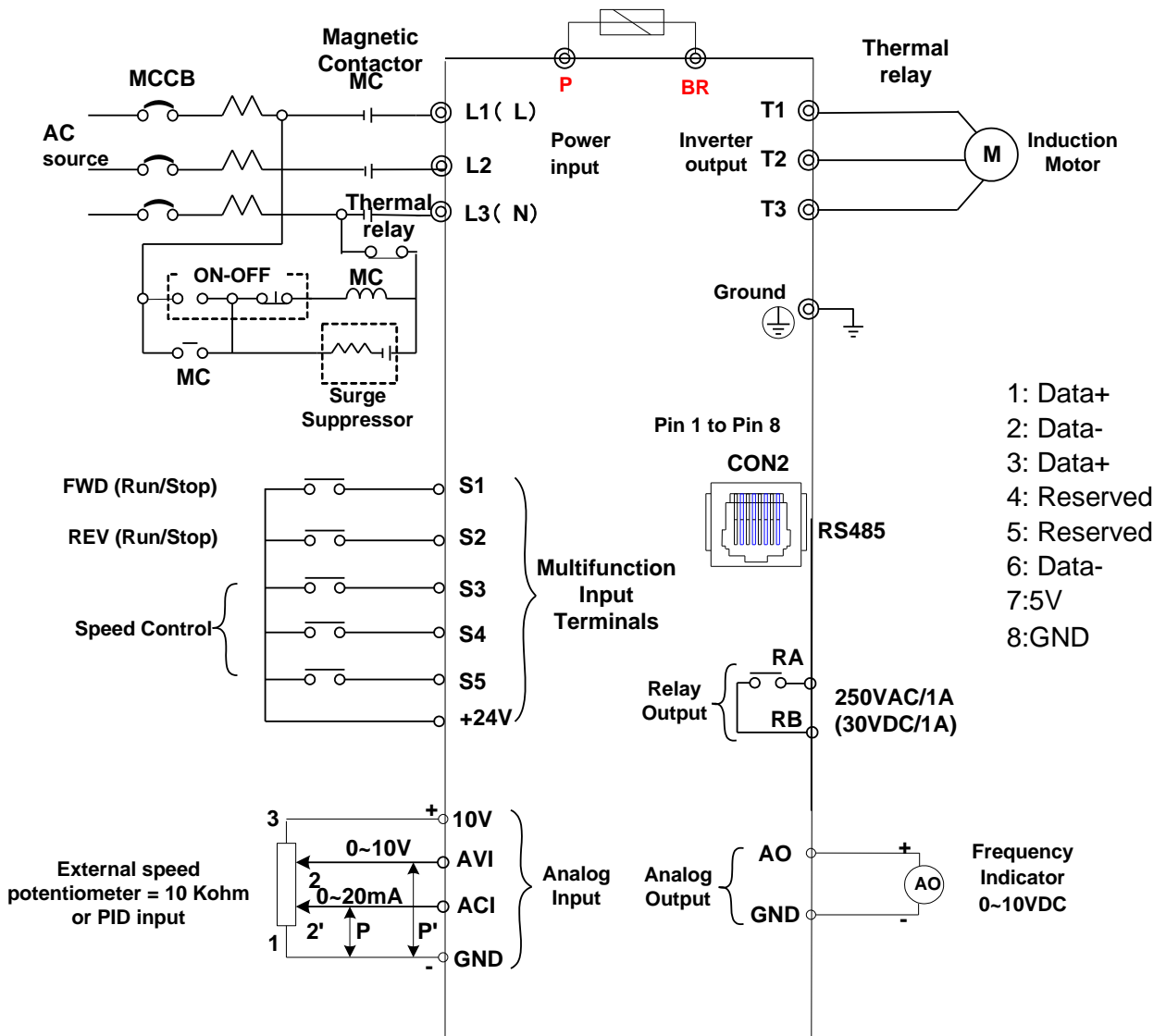

**Model 400V:**

- BL51-40P75-H3X-P
- BL51-401P5-H3X-P
- BL51-402P2-H3X-P

### 3.3.3 400V three phase: BL51-403P7~4011P

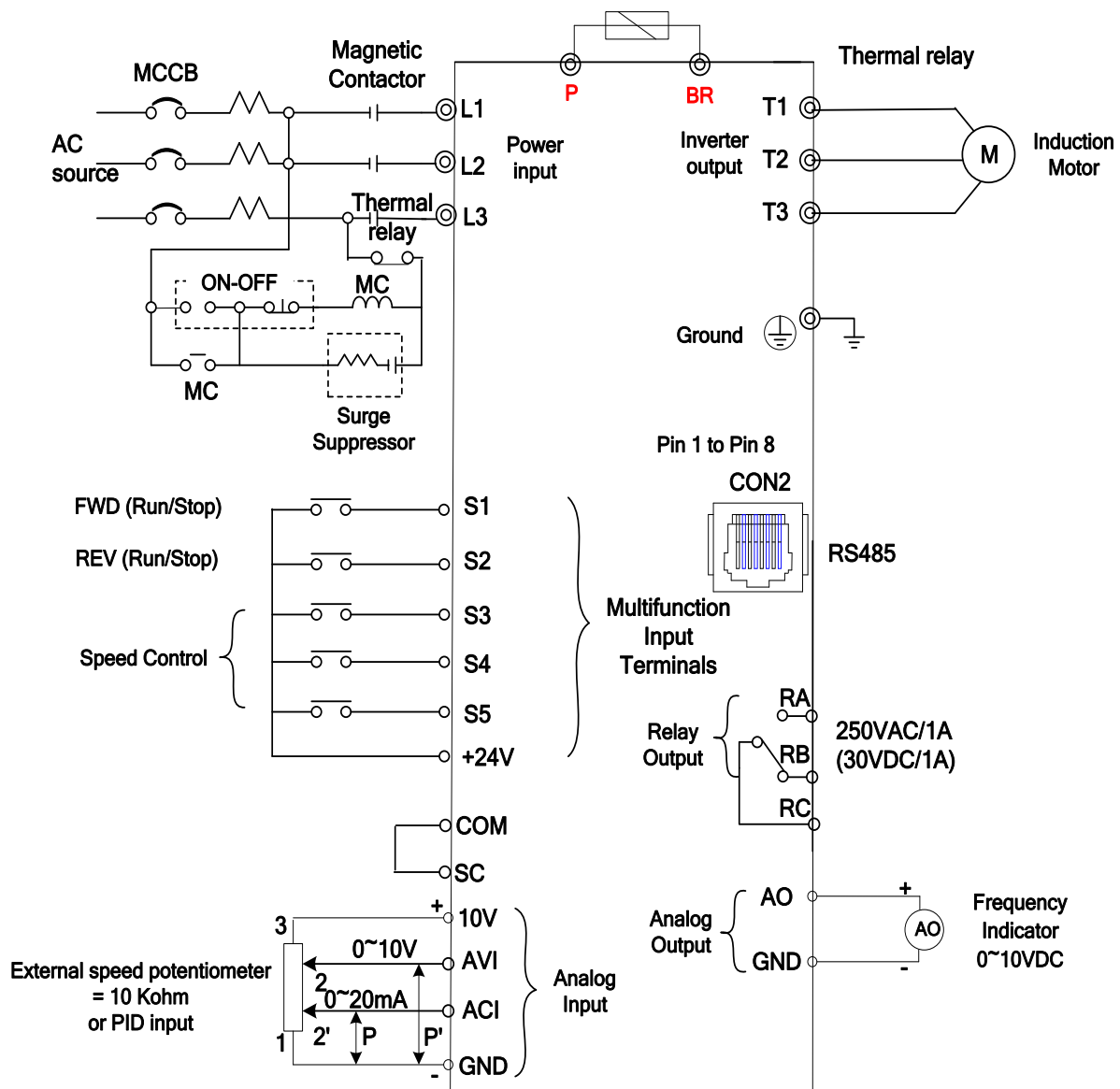

Model 400V:

- BL51-403P7-H3x-P
- BL51-405P5-H3x-P
- BL51-407P5-H3x-P
- BL51-4011P-H3x-P

NPN/PNP input type selection

- PNP: 1.Link SC and COM terminal
- 2.Use +24v terminal for S1~S5 common point

- NPN: 1.Link SC and +24V terminal
- 2.Use COM terminal for S1~S5 common point

Note: For proper working of group 3 functions, the SC terminal must be connected correctly.

### 3.3.4 Single/Multi-Pump Dedicated Wiring Diagram (When 14-00=1)

(For example: NPN input type)

**PUMP Wiring Diagram for Pressure sensor of Current Type:**

**Single Pump:**

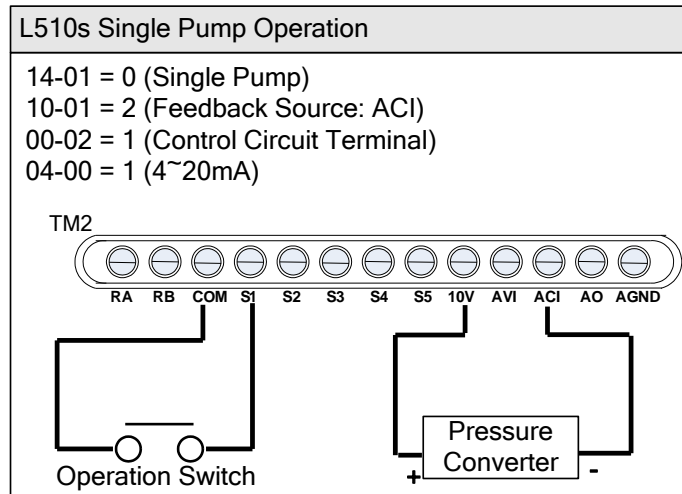

**Multi-Pump:**

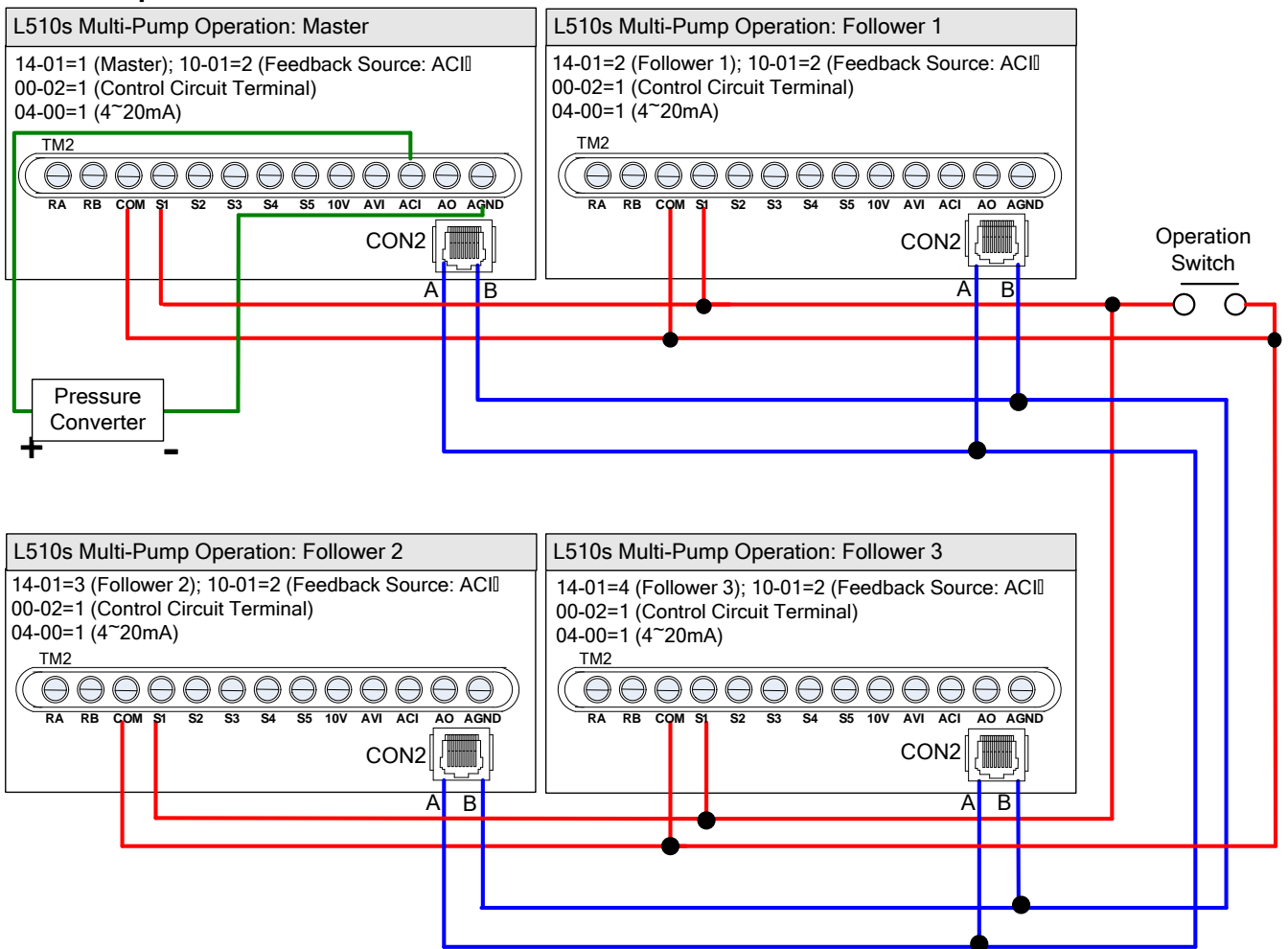

**PUMP Wiring Diagram for Pressure sensor of Voltage Type:  
Single Pump:**

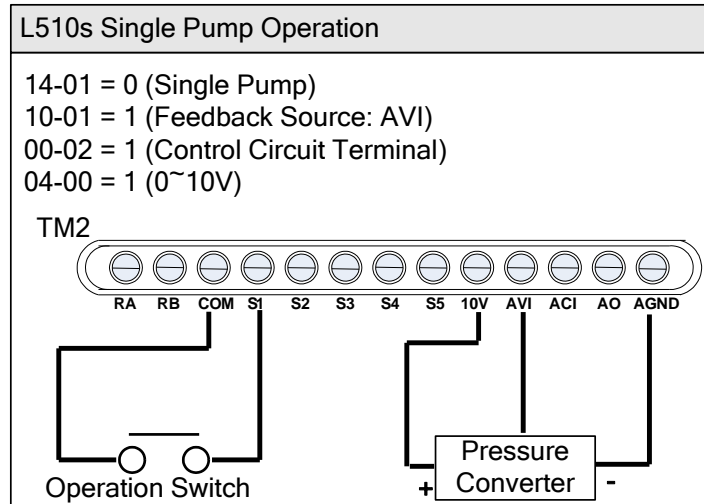

**Multi-Pump:**

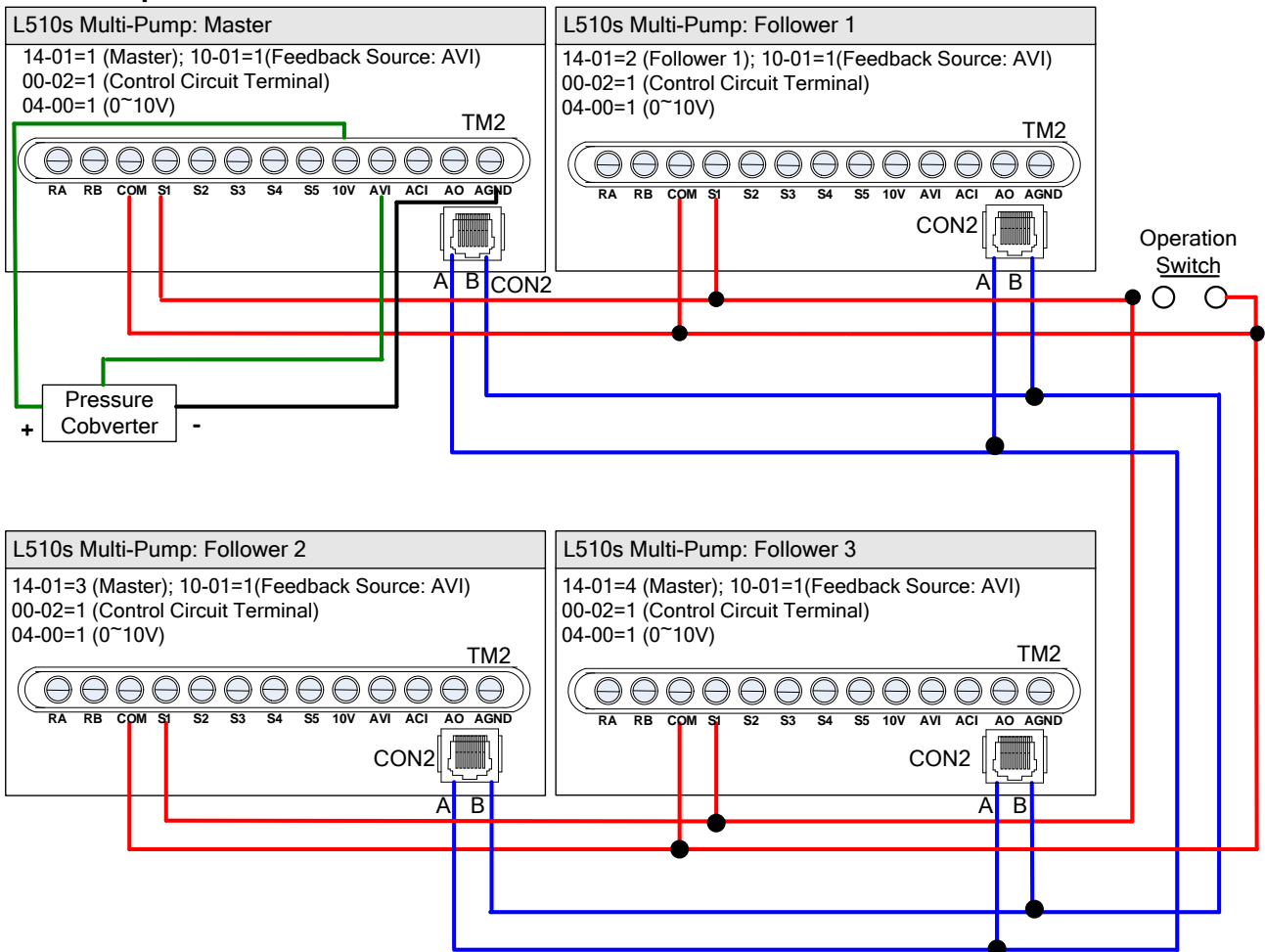

**Notes:**

1. It is required to reconnect after setting Master and Slave.
2. It is required to short the COM and AGND port of frame3 and frame 4 when pressure converter connected with +24Vpower supply.
3. When the communication modes is selected to be multiple pumps in parallel connection, the baud rate setting 09-02 of Master and Slave are required to be consistent. Refer to parameter 14-31 for the actions in parallel connection modes.

## 3.4 Terminal Description

### 3.4.1 Description of main circuit terminals

Terminal symbols	TM1 Function Description
L1(L)	Main power input, Single phase: <b>L1(L)</b> 、 <b>L3(N)</b> Three phase (400V): <b>L1</b> 、 <b>L2</b> 、 <b>L3</b>
L2	
L3(N)	
P*	externally connected braking resistor
BR*	
T1	Inverter output, connect to U, V, W terminals of motor
T2	
T3	
	Ground terminal

\*P, BR for 40XXX series

#### Single phase (20XXX) series

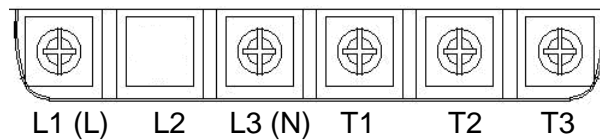

Note: the screw on L2 terminal is removed for the single phase input supply models.

#### Three phase (40XXX series)

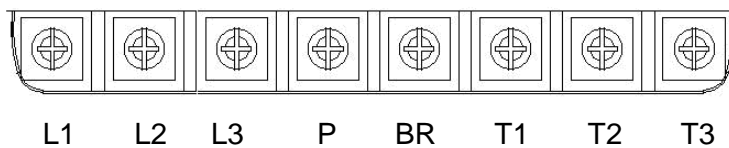

### 3.4.2 Control circuit terminal description

#### Frame1&Frame2

Terminal symbols	TM2 Function Description	Signal Level
RA	Relay output terminal, Specification: 250VAC/1A(30VDC/1A)	250VAC/1A(30VDC/1A)
RB		
COM	S1~S5 (COMMON) 【NPN】	±15%,Max output current 30mA
24V	S1~S5 (COMMON) 【PNP】	
S1~S5	Multi-function input terminals(refer to group3)	24 VDC, 4.5mA, Optical coupling isolation ( Max voltage 30Vdc, Input impedance 6kΩ)
10V	Built in power for an external speed potentiometer	10V,(Max current:20mA)
AVI	Analog voltage input, Specification : 0/2~10VDC (choose by parameter 04-00)	0~10V(Input impedance 200kΩ)
ACI	Analog current input, Specification : 0/4~20mA (choose by parameter 04-00)	0~20mA(Input impedance 499Ω)
AO	Multi function analog output terminal. Maximum output 10VDC/1mA	0~10V(Max current 2mA)
AGND	Analog ground terminal	

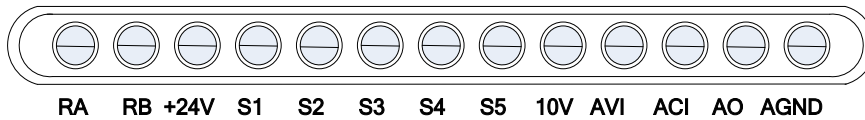

## Frame3&Frame4

Terminal symbols	TM1 Function Description
RA	Relay output terminal, Specification: 250VAC/5A(30VDC/5A) RA: Normally open, RB: Normally close, RC: common point.
RB	
RC	

Terminal symbols	TM2 Function Description	Signal Level
+24V	Common point of PNP input	±15%,Max output current 30mA
SC	NPN/PNP selectable terminal. NPN input: +24V&SC need to be shorted. PNP input: COM&SC need to be shorted.	
COM	voltage reference point for S1~S5	
S1~S5	Multi-function input terminals(refer to group3)	24 VDC, 4.5 mA, Optical coupling isolation (Max.voltage30 Vdc, Input impedance 6kΩ)
10V	Built in Power for an external speed potentiometer (Max output : 20mA)	10V,(Max current:20mA)
AVI/PTC	Analog voltage input/motor over temperature protection signal input, Specification : 0~10VDC	0~10V(Input impedance 200kΩ)
ACI	Analog current input, Specification : 0~20mA / 4~20mA(choose by parameter 04-00)	0~20mA(Input impedance 499Ω)
AO	Multi function analog output terminal. Maximum output 10VDC/1mA	0~10V(Max current 2mA)
AGND	Analog ground terminal	

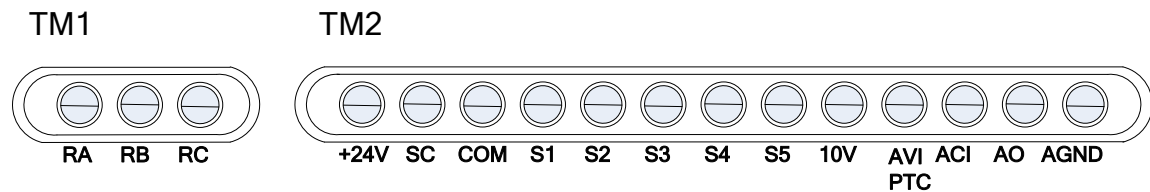

### 3.5 Out line Dimensions (unit: mm)

Tolerance Table				
0~6±0.8	6~30±1.5	30~120±2.5	120~315±4.0	315~1000±6.0

#### Frame1

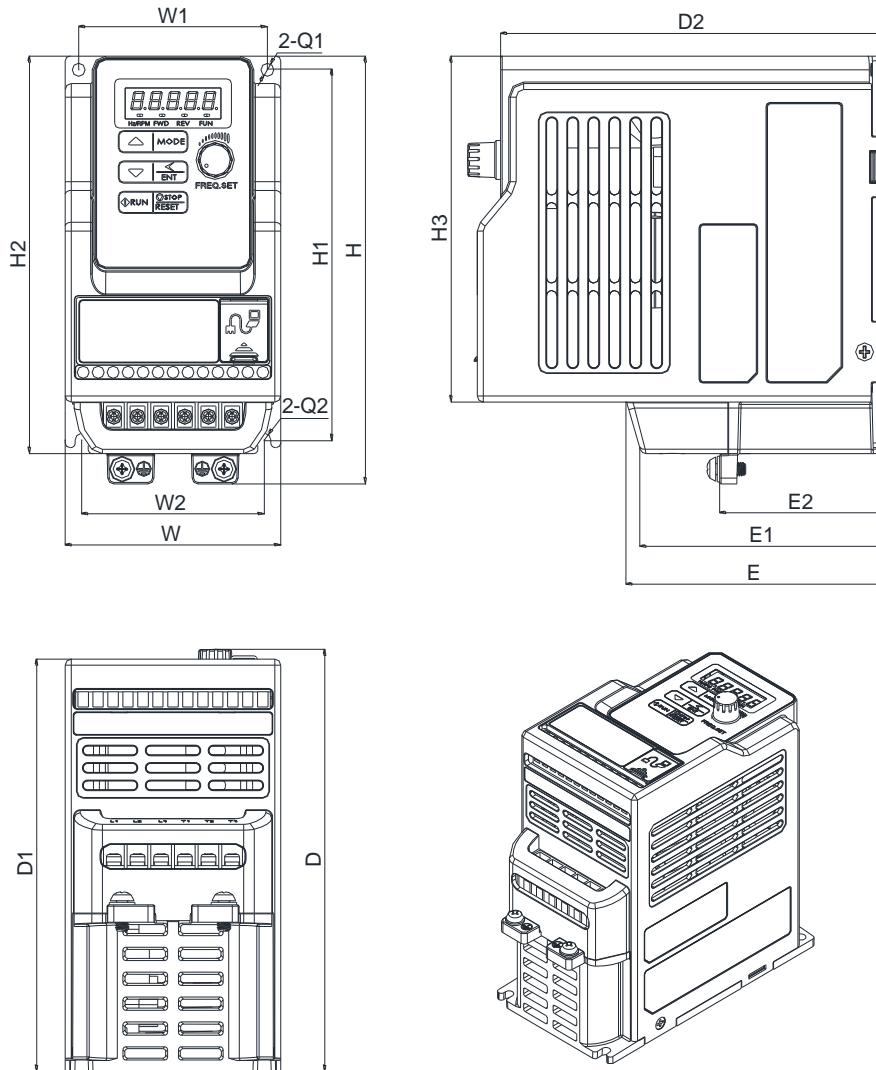

Model	dimension														
	W	W1	W2	H	H1	H2	H3	D	D1	D2	E	E1	E2	Q1	Q2
BL51-20P75-H1X-P	72	63	61	141	131	122	114	141	136	128.2	86.3	81.1	55	4.4	2.2

# Frame2 (200V)

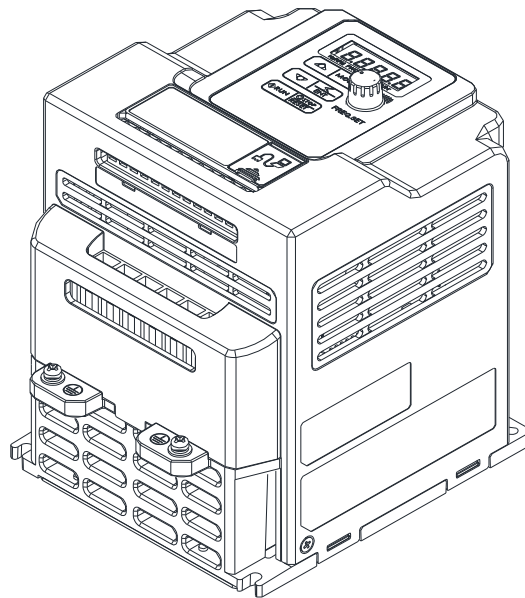
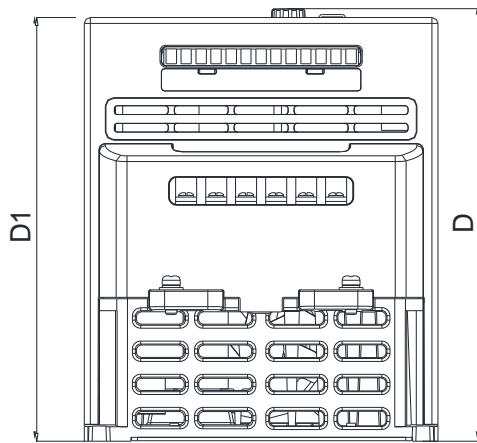
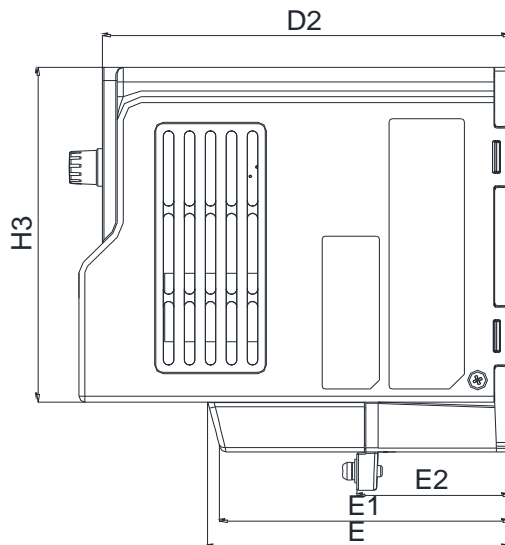
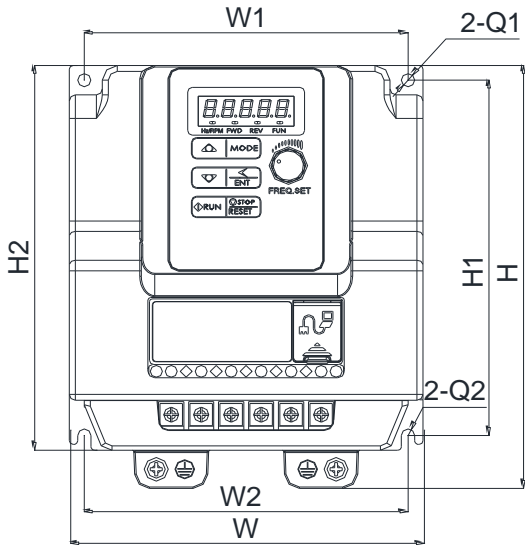

Model	dimension														
	W	W1	W2	H	H1	H2	H3	D	D1	D2	E	E1	E2	Q1	Q2
BL51-201P5-H1X-P	118	108	108	144	131	121	114	150	144.2	136.4	101.32	96.73	51.5	4.4	2.2
BL51-202P2-H1X-P															

# Frame2 (400V)

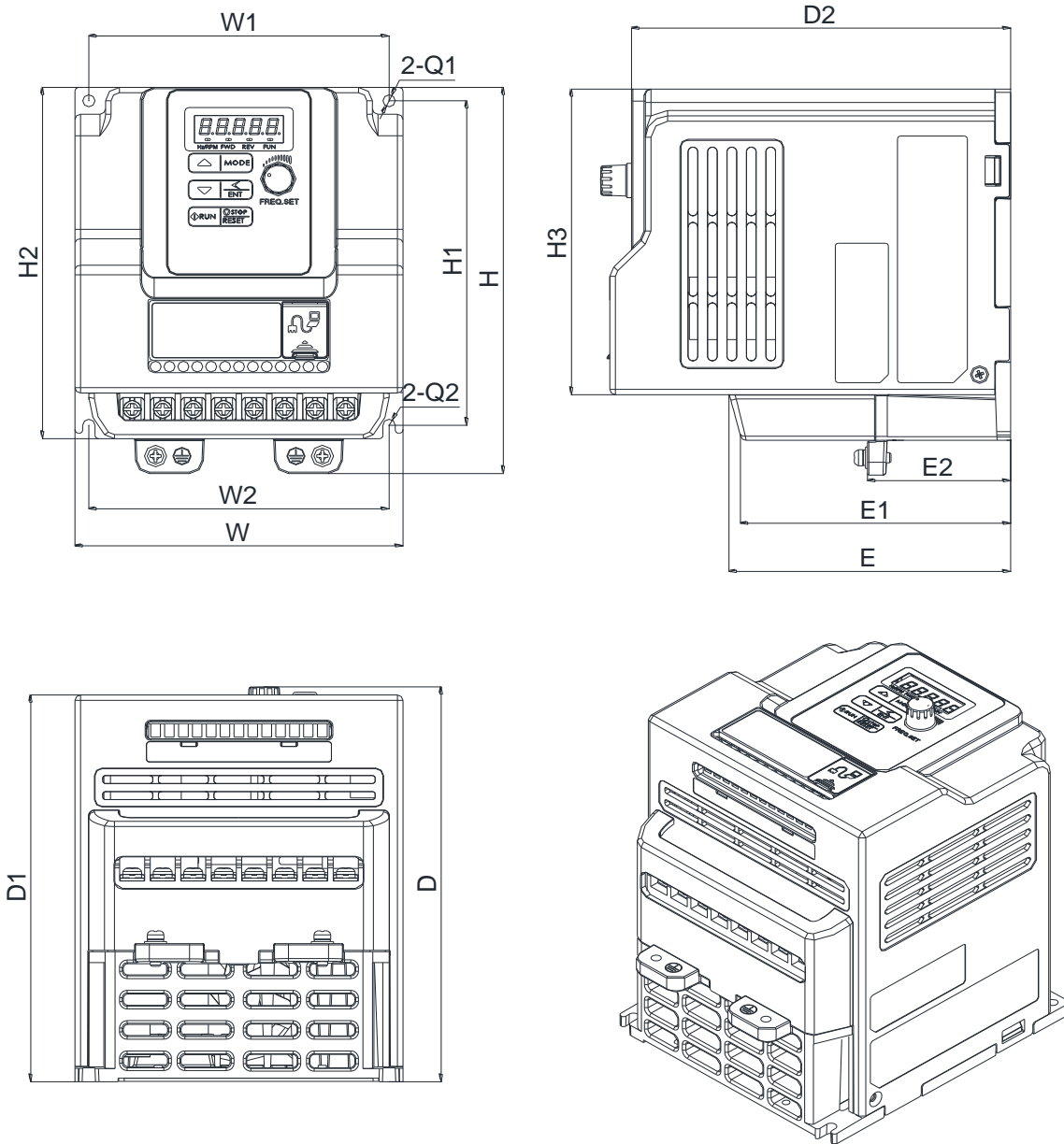

Model	dimension														
	W	W1	W2	H	H1	H2	H3	D	D1	D2	E	E1	E2	Q1	Q2
BL51 – 40P75 – H3X - P	118	108	108	144	131	121	114	150	144.2	136.4	101.32	96.73	51.5	4.3	2.2
BL51 – 401P5 – H3X - P															
BL51 – 402P2 – H3X - P															

# Frame3 (400V)

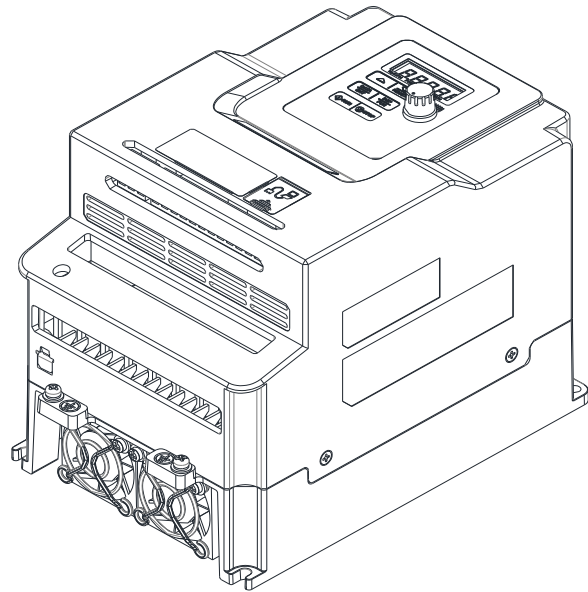
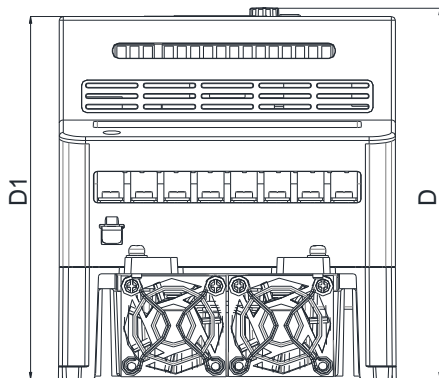
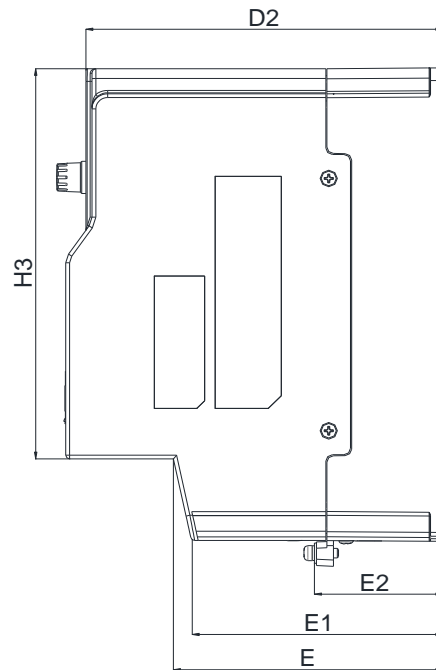
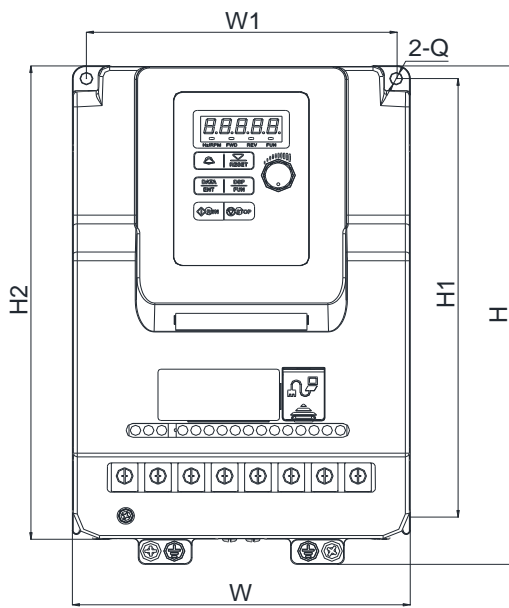

Model	dimension												
	W	W1	H	H1	H2	H3	D	D1	D2	E	E1	E2	Q
BL51 – 403P7 – H3X - P	129	118	197.5	177.6	188	154.7	148	143.7	136	102.6	96	48.2	4.5
BL51 – 405P5 – H3X - P													

# Frame 4 (400V)

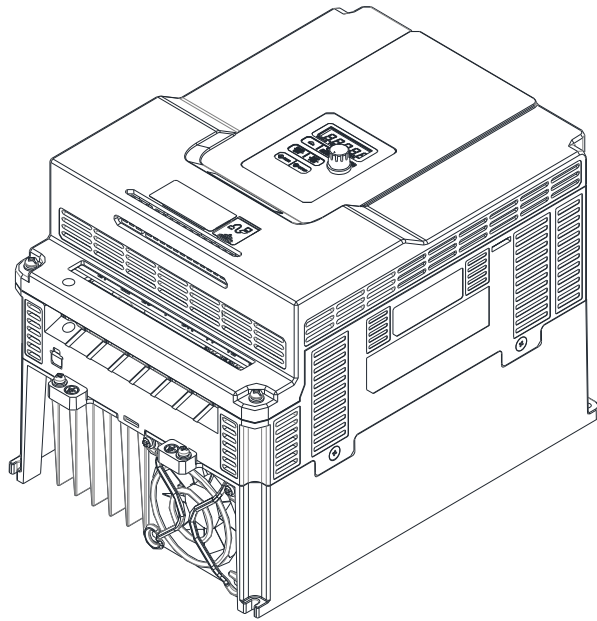
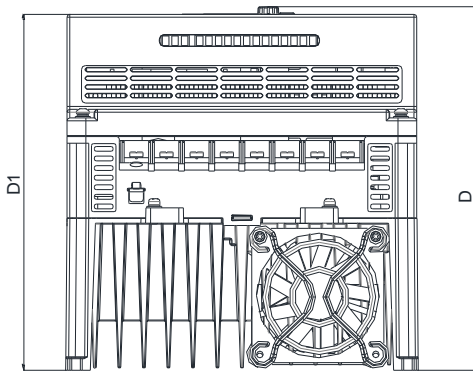
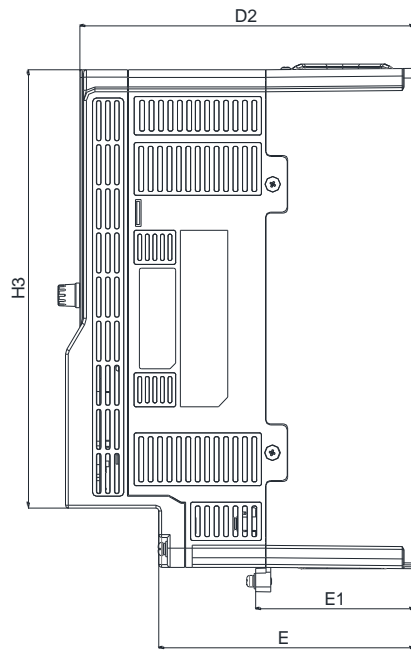
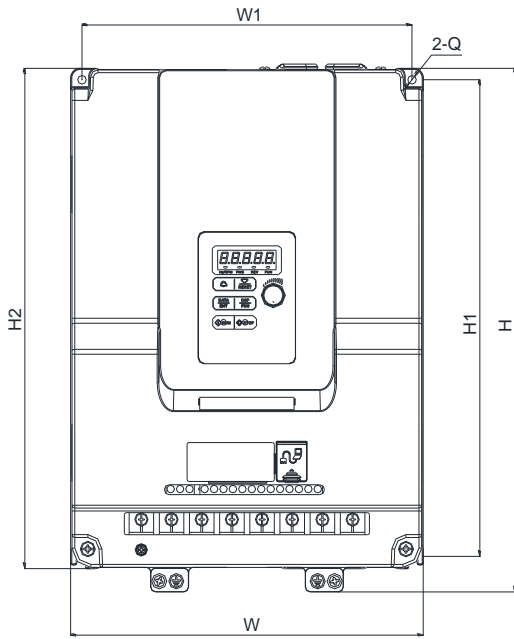

Model	dimension											
	W	W1	H	H1	H2	H3	D	D1	D2	E	E1	Q
BL51-407P5-H3X-P	187	176	273	249.8	261	228.6	190	185.6	177.9	136	84.7	4.5
BL51-4011P-H3X-P												

# Chapter4 Software Index

## 4.1 Keypad Description

### 4.1.1 Operator Panel Functions



Type	Item	Function
Digital display & LEDs	Main digital displays	Frequency Display, Parameter, voltage, Current, Temperature, Fault messages.
	LED Status	Hz/RPM: ON when the frequency or line speed is displayed. OFF when the parameters are displayed. FWD: ON while the inverter is running forward. Flashes while stopped. REV: ON while the inverter is running reverse. Flashes while stopped. FUN: ON when the parameters are displayed. OFF when the frequency is displayed.
Variable Resistor	FREQ SET	Used to set the frequency
Keys On Keypad	RUN	RUN: Run at the set frequency.
	STOP/RESET (Dual function keys)	STOP: Decelerate or Coast to Stop. RESET: Use to Reset alarms or resettable faults.
	▲	Increment parameter number and preset values.
	▼	Decrement parameter number and preset values.
	MODE	Switch between available displays
	</ENTER (Dual function keys, a short press for left shift function, a long press for ENTER function)	<” Left Shift: Used while changing the parameters or parameter values ENTER: Used to display the preset value of parameters and for saving the changed parameter values.

## 4.2 Programmable Parameter Groups

Parameter Group No.	Description
Group 00	Basic parameters
Group 01	V/F Pattern selections & setup
Group 02	Motor parameters
Group 03	Multi function digital Inputs/Outputs
Group 04	Analog signal inputs/ Analog output
Group 05	Preset Frequency Selections.
Group 06	Auto Run(Auto Sequencer) function
Group 07	Start/Stop command setup
Group 08	Drive and motor Protection
Group 09	Communication function setup
Group 10	PID function setup
Group 11	Performance control functions
Group 12	Digital Display & Monitor functions
Group 13	Inspection & Maintenance function
Group 14	PUMP Application Function

Parameter notes for Parameter Groups		
*1	Parameter can be adjusted during running mode	◇ : Revised in version 06
*2	Cannot be modified in communication mode	
*3	Does not change with factory reset	
*4	Read only	

Group 00- The basic parameters group					
No.	Description	Range	Factory Setting	Unit	Note
00-00	control mode	0:V/F mode 1:SLV mode	0	-	
00-01	Motor rotation	0:Forward 1:Reverse	0	-	*1
00-02	Main Run Source Selection	0:Keypad 1:External Run/Stop Control 2:Communication	1	-	
00-03	Alternative Run Source Selection	0:Keypad 1:External Run/Stop Control 2:Communication	0	-	
00-04	Operation modes for external terminals	0: Forward/Stop-Reverse/Stop 1: Run/Stop-Reverse/Forward 2: 3-Wire Control Mode-Run/Stop 3: 2-Wire self-holding Run/Stop	0	-	◇
00-05	Main Frequency Source Selection	0:Keypad 1:Potentiometer on Keypad 2:External AVI Analog Signal Input 3:External ACI Analog Signal Input 4:External Up/Down Frequency Control 5:Communication setting Frequency 6:PID output frequency	2	-	
00-06	Alternative Frequency Source Selection	0:Keypad 1:Potentiometer on Keypad 2:External AVI Analog Signal Input 3:External ACI Analog Signal Input 4:External Up/Down Frequency Control 5:Communication setting Frequency 6:PID output frequency.	0	-	
00-07	Main and Alternative Frequency Command modes	0: Main Or Alternative Frequency 1: Main frequency+Alternative Frequency	0	-	
00-08	Communication Frequency Command	0.00~599.00		Hz	*4
00-09	Frequency command Save mode (Communication mode)	0:Save the frequency before power down 1:Save the communication frequency	0	-	
00-10	Initial Frequency Selection ( keypad mode)	0:by Current Frequency Command 1:by 0 Frequency Command 2:by 00-11	0	-	
00-11	Initial Frequency Keypad mode	0.00~599.00	50.00/60.00	Hz	
00-12	Frequency Upper Limit	0.01~599.00	50.00/60.00	Hz	
00-13	Frequency Lower Limit	0.00~598.99	0.00	Hz	
00-14	Acceleration Time 1	0.1~3600.0	10.0	s	*1
00-15	Deceleration Time 1	0.1~3600.0	10.0	s	*1
00-16	Acceleration Time 2	0.1~3600.0	10.0	s	*1
00-17	Deceleration Time 2	0.1~3600.0	10.0	s	*1
00-18	Jog Frequency	1.00~25.00	2.00	Hz	*1
00-19	Jog Acceleration Time	0.1~25.5	0.5	s	*1
00-20	Jog Deceleration Time	0.1~25.5	0.5	s	*1
00-21	Application Field Selection	0: Disable 1: Constant Pressure Application	1		◇

Group 01- V/F Pattern selection & Setup					
No.	Description	Range	Factory Setting	Unit	Note
01-00	Volts/Hz Patterns	1~7	1/4	-	
01-01	V/F Max voltage	200V:170.0~264.0 400V:323.0~528.0	Based on 13-08	Vac	
01-02	Max Frequency	0.2 ~ 599.00	50.00/60.00	Hz	
01-03	Max Frequency Voltage Ratio	0.0 ~ 100.0	100.0	%	
01-04	Mid Frequency 2	0.1 ~ 599.00	2.50/3.00	Hz	
01-05	Mid Frequency Voltage Ratio 2	0.0 ~ 100.0	7.5/6.8	%	◇
01-06	Mid Frequency 1	0.1 ~ 599.00	2.50/3.00	Hz	
01-07	Mid Frequency Voltage Ratio 1	0.0 ~ 100.0	7.5/6.8	%	◇
01-08	Min Frequency	0.1 ~ 599.00	1.30/1.50	Hz	
01-09	Min Frequency Voltage Ratio	0.0 ~ 100.0	4.5/3.4	%	◇
01-10	Volts/Hz Curve Modification (Torque Boost)	0 ~ 10.0	0.0	%	*1
01-11	V/F start Frequency	0.00~10.00	0.00	Hz	
01-12	No-load oscillation suppression gain	0.0~200.0	0	%	
01-13	Motor Hunting Prevention Coefficient	1~8192	800		
01-14	Motor Hunting Prevention Gain	0~100	0	%	◇
01-15	Motor Hunting Prevention Limit	0~100.0	5.0	%	
01-16	Auto-Torque Compensation Filter Coefficient	0.1~1000.0	0.1	ms	
01-17	Auto-torque Compensation Gain	0~100	0	%	
01-18	Auto-torque Compensation Frequency	1.30~5.00	2	Hz	

Group 02- Motor parameters					
No.	Description	Range	Factory Setting	Unit	Note
02-00	Motor No Load Current	----	by motor nameplate	A	*4
02-01	Motor Rated Current (OL1)	----	by motor nameplate	A	*4
02-02	V/F Slip Compensation	0.0 ~ 100.0	0.0	%	*1
02-03	Motor Rated Speed	----	by motor nameplate	Rpm	*4
02-04	Motor Rated Voltage	----	by motor nameplate	Vac	*4
02-05	Motor Rated Power	0~22.0	by motor nameplate	kW	
02-06	Motor Rated Frequency	0~599.0	by motor nameplate		
02-07	Motor Auto Tuning	0: Disable 1: Static auto tuning	0		
02-08	Stator Resistor Gain	0~600	by series		
02-09	Rotor Resistor Gain	0~600	by series		
02-10	Reserved				
02-11	Reserved				
02-12	Reserved				
02-13	SLV Slip Compensation Gain	0~200	by series	%	
02-14	SLV Torque Compensation Gain	0~200	100	%	
02-15	Low Frequency Torque Gain	0~100	50	%	
02-16	SLV Without Load Slip Compensation Gain	0~200	by series	%	
02-17	SLV With Load Slip	0~200	150	%	

Group 02- Motor parameters					
No.	Description	Range	Factory Setting	Unit	Note
	Compensation Gain				
02-18	SLV With Load Torque Compensation Gain	0~200	100	%	
02-19	SLV Slip Compensation Select	0: Slip Compensation 1 2: Slip Compensation 2	0		

Group 03- Multi function Digital Inputs/Outputs					
No.	Description	Range	Factory Setting	Unit	Note
03-00	Multifunction Input Term. S1	0: Forward/Stop Command 1: Reverse/Stop Command 2: Preset Speed 1 (5-02) 3: Preset Speed 2 (5-03) 4: Preset Speed 4 (5-05) 6: Jog Forward Command 7: Jog Reverse Command 8: Up Command 9: Down Command 10: Acc/Dec 2 11: Acc/Dec Disabled 12: Main/Alternative Run Command select 13: Main/Alternative Frequency Command select 14: Rapid Stop ( Decel to stop) 15: Base Block 16: Disable PID Function 17: Reset 18: Auto Run Mode enable 19: Forced Frequency Run(pump model only) 20: Switch to Constant Pressure 2(pump model only)	0	-	
03-01	Multifunction Input Term. S2		1	-	
03-02	Multifunction Input Term. S3		2	-	
03-03	Multifunction Input Term. S4		3	-	
03-04	Multifunction Input Term. S5		17	-	
03-05	Reserved				
03-06	Up/Down frequency band	0.00~5.00	0.00	Hz	
03-07	Up/Down Frequency modes	0: Preset frequency is held as the inverter stops, and UP/Down function is disabled. 1: Preset frequency is reset to 0 Hz as the inverter stops. 2: Preset frequency is held as the inverter stops, and the UP/Down is available.	0	-	
03-08	S1~S5 scan confirmation	1~200. Number of Scan cycles	10	2ms	
03-09	S1~ S5 switch type select	xxxx0:S1 NO    xxx1:S1 NC xxx0x:S2 NO    xxx1x:S2 NC xx0xx:S3 NO    xx1xx:S3 NC x0xxx:S4 NO    x1xxx:S4 NC 0xxxx:S5 NO    1xxxx:S5 NC	00000	-	
03-10	Reserved				

**Group 03- Multi function Digital Inputs/Outputs**

No.	Description	Range	Factory Setting	Unit	Note	
03-11	Output Relay(RY1)	0: Run 1: Fault 2: Setting Frequency Reached 3: Frequency Reached (3-13±3-14) 4: Output Frequency Detection1(> 3-13) 5: Output Frequency Detection2(< 3-13) 6: Auto-Restart 7: Momentary AC Power Loss 8: Rapid Stop 9: Base Block 10: Motor Overload Protection(OL1) 11: Drive Overload Protection(OL2) 12: Reserved 13: Output Current Reached 14: Brake Control 15: PID feedback disconnection detection 16: High Pressure Detection 17: Low Pressure Detection 18: Pressure Loss Detection	1	-		
03-12	Reserved					
03-13	Output frequency detection level (Hz)	0.00~599.00	0.00	Hz	*1	
03-14	Frequency Detection band	0.00~30.00	2.00	Hz	*1	
03-15	Output Current Detection Level	0.1~999.9	0.1	A		
03-16	Output Current Detection Period	0.1~10.0	0.1	s		
03-17	External Brake Release level	0.00~20.00	0.00	Hz		
03-18	External Brake Engage Level	0.00~20.00	0.00	Hz		
03-19	Relay Output function type	0:A (Normally open) 1:B (Normally close)	0	-		
03-20	Braking Transistor On Level	100/200V: 240.0~400.0V 400V: 500.0~800.0V	100/220/230V:	380	VDC	◇
			380/400V:	690		
			415/460V:	780		
03-21	Brake Transistor Off Level	100/200V: 240.0~400.0V 400V: 500.0~800.0V	100/220/230V:	360	VDC	◇
			380/400V:	650		
			415/460V:	740		

※ "NO" indicates normally open, "NC" indicates normally closed.

**Group 04- Analog signal inputs/ Analogue output functions**

No.	Description	Range	Factory Setting	Unit	Note	
<b>04-00</b>	AVI/ACI analog Input signal type select	<b>AVI</b>	<b>ACI</b>			
		0:	0~10V	0~20mA	0	-
		1:	0~10V	4~20mA		
		2:	2~10V	0~20mA		
3:	2~10V	4~20mA				
<b>04-01</b>	AVI Signal Verification Scan rate	1~200	50	2ms		
<b>04-02</b>	AVI Gain	0~1000	100	%	*1	
<b>04-03</b>	AVI Bias	0~100	0	%	*1	
<b>04-04</b>	AVI Bias Selection	0: Positive 1: Negative	0	-	*1	
<b>04-05</b>	AVI Slope	0: Positive 1: Negative	0	-	*1	
<b>04-06</b>	ACI Signal Verification Scan rate	1~200	50	2ms		
<b>04-07</b>	ACI Gain	0~1000	100	%	*1	
<b>04-08</b>	ACIBias	0~100	0	%	*1	
<b>04-09</b>	ACI Bias Selection	0: Positive 1: Negative	0	-	*1	
<b>04-10</b>	ACI Slope	0: Positive 1: Negative	0	-	*1	
<b>04-11</b>	Analog Output mode (AO)	0: Output Frequency 1: Frequency Command 2: Output Voltage 3: DC Bus Voltage 4: Motor Current	0	-	*1	
<b>04-12</b>	Analog Output AO Gain (%)	0~1000	100	%	*1	
<b>04-13</b>	Analog Output AO Bias (%)	0~1000	0	%	*1	
<b>04-14</b>	AO Bias Selection	0: Positive 1: Negative	0	-	*1	
<b>04-15</b>	AO Slope	0: Positive 1: Negative	0	-	*1	
<b>04-16</b>	Potentiometer Gain on Keypad	0~1000	100	%	*1	
<b>04-17</b>	Potentiometer Bias on Keypad	0~100	0	%	*1	
<b>04-18</b>	Potentiometer Bias Selection on Keypad	0: Positive 1: Negative	0	-	*1	
<b>04-19</b>	Potentiometer Slop on Keypad	0: Positive 1: Negative	0	-	*1	

**Group 05- Preset Frequency Selections.**

No.	Description	Range	Factory Setting	Unit	Note
<b>05-00</b>	Preset Speed Control mode Selection	0: Common Accel/Decel Accel/Decel 1 or 2 apply to all speeds 1: Individual Accel/Decel Accel/ Decel 0-7 apply to the selected preset speeds (Acc0/Dec0~ Acc7/Dec7)	0	-	
<b>05-01</b>	Preset Speed 0 (Keypad Freq)	0.00 ~ 599.00	5.00	Hz	*1
<b>05-02</b>	Preset Speed1	0.00 ~ 599.00	5.00	Hz	*1
<b>05-03</b>	Preset Speed2	0.00 ~ 599.00	10.00	Hz	*1
<b>05-04</b>	Preset Speed3	0.00 ~ 599.00	20.00	Hz	*1
<b>05-05</b>	Preset Speed4	0.00 ~ 599.00	30.00	Hz	*1
<b>05-06</b>	Preset Speed5	0.00 ~ 599.00	40.00	Hz	*1
<b>05-07</b>	Preset Speed6	0.00 ~ 599.00	50.00	Hz	*1
<b>05-08</b>	Preset Speed7	0.00 ~ 599.00	50.00	Hz	*1
<b>05-09 ~ 05-16</b>	Reserved				
<b>05-17</b>	Preset Speed0-Acctime	0.1 ~ 3600.0	10.0	s	*1
<b>05-18</b>	Preset Speed0-Dectime	0.1 ~ 3600.0	10.0	s	*1
<b>05-19</b>	Preset Speed1-Acctime	0.1 ~ 3600.0	10.0	s	*1
<b>05-20</b>	Preset Speed1-Dectime	0.1 ~ 3600.0	10.0	s	*1
<b>05-21</b>	Preset Speed2-Acctime	0.1 ~ 3600.0	10.0	s	*1
<b>05-22</b>	Preset Speed2-Dectime	0.1 ~ 3600.0	10.0	s	*1
<b>05-23</b>	Preset Speed3-Acctime	0.1 ~ 3600.0	10.0	s	*1
<b>05-24</b>	Preset Speed3-Dectime	0.1 ~ 3600.0	10.0	s	*1
<b>05-25</b>	Preset Speed4-Acctime	0.1 ~ 3600.0	10.0	s	*1
<b>05-26</b>	Preset Speed4-Dectime	0.1 ~ 3600.0	10.0	s	*1
<b>05-27</b>	Preset Speed5-Acctime	0.1 ~ 3600.0	10.0	s	*1
<b>05-28</b>	Preset Speed5-Dectime	0.1 ~ 3600.0	10.0	s	*1
<b>05-29</b>	Preset Speed6-Acctime	0.1 ~ 3600.0	10.0	s	*1
<b>05-30</b>	Preset Speed6-Dectime	0.1 ~ 3600.0	10.0	s	*1
<b>05-31</b>	Preset Speed7-Acctime	0.1 ~ 3600.0	10.0	s	*1
<b>05-32</b>	Preset Speed7-Dectime	0.1 ~ 3600.0	10.0	s	*1

### Group 06- Auto Run(Auto Sequencer) function

No.	Description	Range	Factory Setting	Unit	Note
06-00	Auto Run (sequencer) mode selection	0: Disabled. 1: Single cycle. (Continues to run from the Unfinished step if restarted). 2: Periodic cycle. (Continues to run from the unfinished step if restarted). 3: Single cycle, then holds the speed Of final step to run. (Continues to run from the unfinished step if restarted). 4: Single cycle. (Starts a new cycle if restarted). 5: Periodic cycle. (Starts a new cycle if restarted). 6: Single cycle, then hold the speed of final step to run (Starts a new cycle if restarted).	0	-	
06-01	Auto _ Run Mode frequency command 1	0.00~599.00	0.00	Hz	*1
06-02	Auto _ Run Mode frequency command 2	0.00~599.00	0.00	Hz	*1
06-03	Auto _ Run Mode frequency command 3	0.00~599.00	0.00	Hz	*1
06-04	Auto _ Run Mode frequency command 4	0.00~599.00	0.00	Hz	*1
06-05	Auto _ Run Mode frequency command 5	0.00~599.00	0.00	Hz	*1
06-06	Auto _ Run Mode frequency command 6	0.00~599.00	0.00	Hz	*1
06-07	Auto _ Run Mode frequency command 7	0.00~599.00	0.00	Hz	*1
06-16	Auto_ Run Mode running time setting 0	0.0 ~ 3600.0	0.0	s	*1
06-17	Auto_ Run Mode running time setting 1	0.0 ~ 3600.0	0.0	s	*1
06-18	Auto_ Run Mode running time setting 2	0.0 ~ 3600.0	0.0	s	*1
06-19	Auto_ Run Mode running time setting 3	0.0 ~ 3600.0	0.0	s	*1
06-20	Auto_ Run Mode running time setting 4	0.0 ~ 3600.0	0.0	s	*1
06-21	Auto_ Run Mode running time setting 5	0.0 ~ 3600.0	0.0	s	*1
06-22	Auto_ Run Mode running time setting 6	0.0 ~ 3600.0	0.0	s	*1
06-23	Auto_ Run Mode running time setting 7	0.0 ~ 3600.0	0.0	s	*1
06-32	Auto_ Run Mode running direction 0	0: Stop    1: Forward    2: Reverse	0	-	
06-33	Auto_ Run Mode running direction 1	0: Stop    1: Forward    2: Reverse	0	-	
06-34	Auto_ Run Mode running direction 2	0: Stop    1: Forward    2: Reverse	0	-	
06-35	Auto_ Run Mode running direction 3	0: Stop    1: Forward    2: Reverse	0	-	

**Group 06- Auto Run(Auto Sequencer) function**

No.	Description	Range	Factory Setting	Unit	Note
06-36	Auto_Run Mode running direction 4	0: Stop 1: Forward 2: Reverse	0	-	
06-37	Auto_Run Mode running direction 5	0: Stop 1: Forward 2: Reverse	0	-	
06-38	Auto_Run Mode running direction 6	0: Stop 1: Forward 2: Reverse	0	-	
06-39	Auto_Run Mode running direction 7	0: Stop 1: Forward 2: Reverse	0	-	

**Group 07- Start/Stop command setup**

No.	Description	Range	Factory Setting	Unit	Note
07-00	Momentary Power Loss and Restart	0: Momentary Power Loss and Restart disable 1: Momentary power loss and restart enable	0	s	
07-01	Auto Restart Delay Time	0.0~6000.0	0.0	s	
07-02	Number of Auto Restart Attempts	0~10	0	-	
07-03	Reset Mode Setting	0: Enable Reset Only when Run Command is Off 1: Enable Reset when Run Command is On or Off	0	-	
07-04	Direct Running After Power Up	0: Enable Direct run on power up 1: Disable Direct run on power up	1	-	
07-05	Delay-ON Timer	1.0~300.0	1.0	s	
07-06	DC Injection Brake Start Frequency (Hz) In Stop mode	0.10 ~ 10.00	1.5	Hz	
07-07	DC Injection Brake Level (%) In stop mode	0 ~ 20 (Frame1/2). Based on the 20% of maximum output voltage	5	%	
		0 ~ 100 (Frame3/4) based on the rated current	50		
07-08	DC Injection Brake Time (Seconds) In stop mode	0.0 ~ 25.5	0.5	s	
07-09	Stopping Method	0: Deceleration to stop 1: Coast to stop	0		
07-10	DC Braking Level at Start	0 ~ 20 (Frame1/2). Based on the 20% of maximum output voltage	0	%	
		0 ~ 100 (Frame3/4) based on the rated current	50	%	
07-11	DC Braking Time at Start	0.0~25.5	0.0	s	
07-12	Run Command Retention	0: Run command retention during power loss 1: Run command not retained during power loss	1		

**Group 08- Drive & Motor Protection functions**

No.	Description	Range	Factory Setting	Unit	Note
08-00	Trip Prevention Selection	xxxx0: Enable Trip Prevention During Acceleration xxxx1: Disable Trip Prevention During Acceleration xxx0x: Enable Trip Prevention During Deceleration xxx1x: Disable Trip Prevention During Deceleration xx0xx: Enable Trip Prevention in Run Mode xx1xx: Disable Trip Prevention in Run Mode x0xxx: Enable over voltage Prevention in Run Mode x1xxx: Disable over voltage Prevention in Run Mode	00000	-	
08-01	Trip Prevention Level During Acceleration (%)	50 ~ 200	by series	Inverter Rated Current 100%	
08-02	Trip Prevention Level During Deceleration (%)	50 ~ 200	by series		
08-03	Trip Prevention Level In Run Mode (%)	50 ~ 200	by series		
08-04	over voltage Prevention Level in Run Mode	200V: 350.0~390.0 400V: 700.0~780.0	380.0/760.0	VDC	*1
08-05	Electronic Motor Overload Protection Operation Mode	xxxx0: Disable Electronic Motor Overload Protection xxxx1: Enable Electronic Motor Overload Protection xxx0x: Motor Overload Cold Start xxx1x: Motor Overload Hot Start xx0xx: Standard Motor xx1xx: Invertor Duty Motor	00001	-	
08-06	Operation After Overload Protection is Activated	0: Coast-to-Stop After Overload Protection is Activated 1: Drive Will Not Trip when Overload Protection is Activated (OL1)	0	-	
08-07	Over heat Protection (cooling fan control)	0: Auto (Depends on temp.) 1: Operate while in RUN mode 2: Always Run 3: Disabled	1	-	
08-08	AVR Function (Auto Voltage Regulation)	0: AVR function enable 1: AVR function Disable 2: AVR function disable for stop 3: AVR function disable for deceleration 4: AVR function disable for stop and deceleration. 5: When VDC>(360V/740V), AVR function disable for stop and deceleration.	4	-	
08-09	Input phase lost protection	0: Disabled 1: Enabled	0	-	

Group 08- Drive & Motor Protection functions					
No.	Description	Range	Factory Setting	Unit	Note
08-10	PTC Overheat Function	0: Disable 1: Decelerate to stop 2: Coast to stop 3: Continue running, when <b>warning level</b> is reached. Coast to stop, when <b>protection level</b> is reached.	0		
08-11	PTC Signal Smoothing Time	0.01~10.00	0.2	Sec	
08-12	PTC Detection Time Delay	1~300	60	Sec	
08-13	PTC Protection Level	0.1~10.0	0.7	V	
08-14	PTC Detection Level Reset	0.1~10.0	0.3	V	
08-15	PTC Warning Level	0.1~10.0	0.5	V	
08-16	Fan Control Temperature Level	10.0~50.0	50.0	°C	
08-17	Over current protection level	0.0 ~ 60.0	0.0	A	
08-18	Over current protection time	0.0 ~ 1500.0	1.0	s	
08-19	Motor Overload Protection Level	0: Motor Overload Protection Level 0 1: Motor Overload Protection Level 1 2: Motor Overload Protection Level 2	0		

Group 09- Communication function setup					
No.	Description	Range	Factory Setting	Unit	Note
09-00	Assigned Communication Station Number	1 ~ 32	1	-	*2*3
09-01	Communication Mode Select	0: Modbus RTU code 1: Modbus ASCII code 2: BACnet	0	-	*2*3
09-02	Baud Rate Setting (bps)	0: 4800 1: 9600 2: 19200 3: 38400 4: Remote Control is enabled	2	bps	*2*3 ◇
09-03	Stop Bit Selection	0: 1 Stop Bit 1: 2 Stop Bits	0	-	*2*3
09-04	Parity Selection	0: Without Parity 1: With Even Parity 2: With Odd Parity	0	-	*2*3
09-05	Data Format Selection	0: 8-Bits Data 1: 7-Bits Data	0	-	*2*3
09-06	Communication time-out detection time	0.0 ~ 25.5	0.0	s	

Group 09- Communication function setup					
No.	Description	Range	Factory Setting	Unit	Note
09-07	Communication time-out operation selection	0: Deceleration to stop (set by 00-15) 1: Coast to stop 2: Deceleration to stop (set by 00-17) 3: continue operating	0	-	
09-08	Error 6 verification time.	0 ~ 20	3		
09-09	Drive Transmit delay Time( ms )	5 ~ 65	5	2ms	
09-10	BACnet stations	1~254	1		*2*3

Group10- PID function Setup					
No.	Description	Range	Factory Setting	Unit	Note
10-00	PID target value selection (when 00-05\00-06=6, this function is enabled)	0: Potentiometer on Keypad 1: Analog Signal Input. (AVI) 2: Analog Signal Input. (ACI) 3: Frequency set by communication 4: 10-02 given 5: Preset frequency	1	-	*1
10-01	PID feedback value selection	0: Potentiometer on Keypad 1: Analog Signal Input. (AVI) 2: Analog Signal Input. (ACI) 3: Communication Setting Frequency	2	-	*1
10-02	PID Target (keypad input)	0.0~100.0	50.0	%	*1
10-03	PID Mode Selection	0: Disabled. 1: Deviation D Control. FWD Characteristic. 2: Feedback D Control. FWD Characteristic 3: Deviation D Control. Reverse Characteristic. 4: Feedback D Control. Reverse Characteristic 5: Frequency Command + Deviation D Control. FWD Characteristic 6: Frequency Command + Feedback D Control FWD Characteristic. 7: Frequency Command + Deviation D Control Reverse Characteristic. 8: Frequency Command + Feedback D Control Reverse Characteristic	0	-	
10-04	Feedback Gain Coefficient	0.00 ~ 10.00	1.00	%	*1
10-05	Proportional Gain	0.0 ~ 10.0	3.0	%	*1
10-06	Integral Time	0.0 ~ 100.0	0.5	s	*1
10-07	Derivative Time	0.00 ~ 10.00	0.00	s	*1
10-08	PID Offset	0: Positive 1: Negative	0	-	*1
10-09	PID Offset Adjust	0 ~ 109	0	%	*1
10-10	PID Output Lag Filter Time	0.0 ~ 2.5	0.0	s	*1
10-11	Feedback Loss Detection Mode	0: Disabled 1: Drive keeps running after feedback loss 2: Drive stops after feedback loss	0	-	
10-12	Feedback Loss Detection Level	0 ~ 100	0	%	
10-13	Feedback Loss Detection Delay Time	0.0 ~25.5	1.0	s	
10-14	Integration Limit Value	0 ~ 109	100	%	*1

Group10- PID function Setup					
No.	Description	Range	Factory Setting	Unit	Note
10-15	Integral Value Resets to Zero when Feedback Signal Equals the Target Value	0: Disabled 1: 1 Second 30: 30 Seconds (0 ~ 30)	0	-	
10-16	Allowable Integration Error. Margin (units)(1unit = 1/8192)	0 ~ 100	0	-	
10-17	PID Sleep Frequency Level	0.00~599.00	0.00	Hz	
10-18	PID Sleep Function Delay Time	0.0 ~25.5	0.0	s	
10-19	PID Wake up frequency Level	0.00 ~ 599.00	0.00	Hz	
10-20	PID Wake up function Delay Time	0.0 ~ 25.5	0.0	s	
10-21	Max PID Feedback Setting	0 ~999	100	-	*1
10-22	Min PID Feedback Setting	0 ~999	0	-	*1

Group11- Performance Control functions					
No.	Description	Range	Factory Setting	unit	Note
11-00	Reverse operation control	0: Reverse command is valid 1: Reverse command is invalid	0	-	
11-01	Carrier Frequency (kHz)	1~16	5	KHz	
11-02	Carrier mode Selection	0: Mode0, 3phase PWM modulation 1: Mode1, 2phase PWM modulation 2: Mode2, random PWM modulation	1	-	
11-03	Carrier Frequency Reduction by temperature rise	0: Disabled 1: Enabled	0	-	
11-04	S-Curve Acc 1	0.0 ~ 4.0	0.00	s	
11-05	S-Curve Acc 2	0.0 ~ 4.0	0.00	s	
11-06	S-Curve Dec 3	0.0 ~ 4.0	0.00	s	
11-07	S-Curve Dec 4	0.0 ~ 4.0	0.00	s	
11-08	Skip Frequency 1	0.00 ~ 599.00	0.00	Hz	*1
11-09	Skip Frequency 2	0.00 ~ 599.00	0.00	Hz	*1
11-10	Skip Frequency 3	0.00 ~ 599.00	0.00	Hz	*1
11-11	Skip Frequency Bandwidth ( $\pm$ )	0.00 ~ 30.00	0.00	Hz	*1
11-12	Reserved				
11-13	Regeneration Prevention Function	0: Disable 1: Enable 2: Enable (during constant speed only)	0	-	
11-14	Regeneration Prevention Voltage Level	200v: 300.0~400.0 400v: 600.0~800.0	380/760	V	
11-15	Regeneration Prevention Frequency Limit	0.00 ~ 15.00	3.00	Hz	
11-16	Regeneration Prevention Voltage Gain	0~200	100	%	
11-17	Regeneration Prevention Frequency Gain	0~200	100	%	
11-18	Speed loop proportion gain	0~65535	10000		
11-19	Speed loop integration gain	0 ~65535	800		
11-20	Speed loop differential gain	0 ~65535	0		
11-21	Stop Key Selection	0: Enable Stop Key when Run Command not from Keypad 1: Disable Stop Key when Run Command not from Keypad	0		

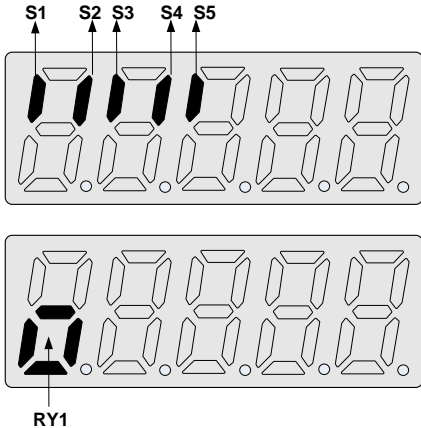

**Group12 Digital Display & Monitor functions**

No.	Description	Range	Factory Setting	Unit	Note
12-00	Extended Display Mode	00000 ~77777. Each digit can be set to 0 to 7 0: Default display(frequency&parameters) 1:Output Current 2:Output Voltage 3:DC voltage 4:Temperature of Heat sink 5:PID feedback 6:Analog Signal Input. (AVI) 7:Analog Signal Input. (ACI)	00321	-	*1
12-01	PID Feedback Display format	0: Integer (xxx) 1: One decimal Place (xx.x) 2: Two Decimal Places (x.xx)	0	-	*1
12-02	PID Feedback Display Unit Setting	0: xxx-- 1: xxxpb (pressure) 2: xxxfl (flow)	0	-	*1
12-03	Custom Units (Line Speed) Value	0~65535	1500/1800	RPM	*1
12-04	Custom Units (Line Speed) Display Mode	0:Drive Output Frequency is Displayed 1:Line Speed. Integer.(xxxxx) 2:Line Speed..One Decimal Place (xxxx.x) 3:Line Speed.Two Decimal Places (xxx.xx) 4:Line Speed.Three Decimal Places (xx.xxx)	0	-	*1
12-05	Inputs and output Logic status display ( S1 to S5) & RY1		-----	-	*4
12-06	Output Power	----	0.0	kW	
12-07	Motor Current Percentage	----	0	%	

### Group 13 Inspection & Maintenance functions

No.	Description	Range	Factory Setting	unit	Note
13-00	Drive Horsepower Code	----	-	-	*3
13-01	Software Version	----	-	-	*3*4
13-02	Fault Log (Last 3 Faults)	----	-	-	*3*4
13-03	Accumulated Operation Time1 1	0~23	-	hour	*3
13-04	Accumulated Operation Time1 2	0~65535	----	day	*3
13-05	Accumulated Operation Time Mode	0: Time Under Power 1: Run Mode Time Only	0	-	*3
13-06	Parameter Lock	0: Enable all Functions 1: Preset speeds 05-01~05-08 cannot be changed 2: All Functions cannot be changed except for Preset speeds 05-01~05-08 3: Disable All Function	0	-	
13-07	Parameter Lock Code	00000~65535	00000	-	
13-08	Restore Factory Settings	1150: Initialization (50Hz,220V/380V) 1160: Initialization (60Hz,220V/380V) 1250: Initialization (50Hz,230V/400V) 1260: Initialization (60Hz,230V/460V) 1350: Initialization (50Hz,220V/415V) 1360: Initialization (60Hz,230V/400V)	1250/1360 (Note)	-	

**Notes:**

For built-in EMC filter models, the default setting of 13-08 is “1250”.

For without built-in EMC filter models, the default setting of 13-08 is “1360”

### Group 14 PUMP Application Function

No.	Description	Range	Factory Setting	unit	Note
14-00	Function Selection	0: Disable 1: PUMP	0	-	
14-01	Setting of Single & Multiple Pumps and Master & Slave Machines	0: Single Pump 1: Master 2: Slave 1 3: Slave 2 4: Slave 3	0	-	
14-02	Operation Pressure Setting	0.1~(the value of 14-03)	4.00	PSI	
14-03	Maximum Pressure Setting of Pressure Transmitter	0.10 ~ 650.00	10.00	PSI	
14-04	Pump Pressure Command Source	0 : Set by 14-02 1 : Set by AI	0	-	
14-05	Display Mode Selection	0: Display of Target and Pressure Feedback (14-03<99) 1: Target Pressure Only 2: Feedback Pressure Only	0	-	
14-06	Proportion Gain(P)	0.00~10.00	3.00	-	
14-07	Integral Time(I)	0.0~100.0	0.5	sec	
14-08	Differential Time(D)	0.00~10.00	0.00	sec	
14-09	Tolerance Range of Constant Pressure	When 14-20=0, range is 0.00~650.00 When 14-20=1, range is 0~100	5	PSI/%	
14-10	Sleep Frequency of Constant Pressure	0.00~599.00	30.00	Hz	
14-11	Sleep Time of Constant Pressure	0.0~255.5	0.0	sec	
14-12	Maximum Pressure Limit	When 14-20=0, range is 0.00~650.00 When 14-20=1, range is 0~100	50	PSI/%	
14-13	Warning Time of High Pressure	0.0~600.0	10	sec	
14-14	Stop Time of High Pressure	0.0~600.0	20	sec	
14-15	Minimum Pressure Limit	When 14-20=0, range is 0.00~650.00 When 14-20=1, range is 0~100	5	PSI/%	
14-16	Warning Time of Low Pressure	0.0~600.0	0.0	sec	
14-17	Fault Stop Time of Low Pressure	0.0~600.0	0.0	sec	
14-18	Time of Loss Pressure Detection	0.0~600.0	0.0	sec	
14-19	Proportion of Loss Pressure Detection	0~100	0	%	
14-20	Switching of Pressure and Percentage	0: Pressure 1: Percentage	1	-	
14-22	Slave Trip Frequency	0.00 ~ 599.00	45.00	Hz	
14-23	Direction of Water Pressure Detection	0: Upward Detection 1: Downward Detection	1	-	

### Group 14 PUMP Application Function

No.	Description	Range	Factory Setting	unit	Note
14-24	Range of Water Pressure Detection	When 14-20=0, range is 0.00~650.00 When 14-20=1, range is 0~100	1	PSI/%	
14-25	Period of Water Pressure Detection	0.0~200.0	30.0	sec	
14-26	Acceleration Time of Water Pressure Detection	0.1~3600.0	12.0	sec	
14-27	Deceleration Time of Water Pressure Detection	0.1~3600.0	35.0	sec	
14-28	Forced Run Command	0.00~(the value of 00-12)	0.00	Hz	
14-29	Switching Time of Water Pressure Detection	0~240	3	Hr	
14-30	Detection Time of Multiple Pumps in Parallel Running Start	0~30.0	0.0	sec	
14-31	Synchronous Selection of Multiple Pumps in Parallel	0: Disable 1: Pressure Setting Run/Stop 2: Pressure Setting 3: Run/Stop	1	-	
14-34	Tolerance Range of Constant Pressure 2	When 14-20=0, range is 0.00~650.00 When 14-20=1, range is 0~100	5	PSI/%	
14-35	Selection of Multiple Pumps Shift Operation	0: No Function 1: Timer Alternately Selection 2: Sleep Stop Alternately Selection 3: Timer and Sleep Stop Alternately Selection 4: Multiple Pumps Test Mode	1	-	
14-37	Leakage Detection Time	0.0~100.0	0.0	sec	
14-38	Pressure Variation of Leakage Detection Restart	When 14-20=0, range is 0.00~65.00 When 14-20=1, range is 0~100	1	PSI/%	
14-39	Pressure Tolerance Range of Leakage Detection Restart	When 14-20=0, range is 0.00~650.00 When 14-20=1, range is 0~100	5	PSI/%	
14-71	Maximum Pressure Setting	0.10~650.00	10	PSI	
14-72	Switching Time of Alternation in Parallel	0: Hour 1: Minute	0	-	
14-73	Slave Wake-Up Selection	0: Disable 1: Enable	0	-	
14-74	Proportion Time 2 (P)	0.00~10.00	3.00		◇
14-75	Integral Time 2 (I)	0.0~100.0	0.5		◇
14-76	Differential Time 2 (D)	0.00~10.00	0.00		◇
14-77	The Value of Water Pressure Detection	0~100	1		◇

**\*\* (Group 14 only can be used once parameter 14-00=1)**

# Chapter 5 Troubleshooting and maintenance

## 5.1 Error display and corrective action

### 5.1.1 Manual Reset and Auto-Reset

Faults which cannot be recovered manually			
Display	Content	Cause	Corrective action
-OV- -OU-	Voltage too high when stopped	Detection circuit malfunction	Consult with the supplier
-LV- -LU-	Voltage too low when stopped	<ul style="list-style-type: none"> <li>Power voltage too low</li> <li>Pre-charge resistor or fuse burnt out.</li> <li>Detection circuit malfunction</li> </ul>	<ul style="list-style-type: none"> <li>Check if the power voltage is correct</li> <li>failed resistor or fuse</li> <li>Consult with the supplier</li> </ul>
-OH- -OH-	The inverter is overheated when stopped	<ul style="list-style-type: none"> <li>Detection circuit malfunction</li> <li>Ambient temperature too high or bad ventilation</li> </ul>	Improve the ventilation conditions, if no result then replace the inverter
OH-C OH-C	The inverter is overheated during running	<ul style="list-style-type: none"> <li>IGBT temperature is too high or poor ventilation</li> <li>Temperature sensor error or circuit malfunctions</li> </ul>	<ul style="list-style-type: none"> <li>Reduce carrier frequency</li> <li>Improve the ventilation conditions, if no result then replace the inverter</li> </ul>
CtEr CtEr	Current Sensor detection error	Current sensor error or circuit malfunction	Consult with the supplier
HPErr HPErr	Inverter capacity setting error: Inverter capacity setting 13-00 does not match the rated voltage.	The inverter capacity setting (13-00) does not match the hardware voltage levels	Check the inverter capacity setting (13-00) to meet the hardware voltage levels.
Err4 Err4	CPU Unusual interruption	External noise interference	<ul style="list-style-type: none"> <li>Remove the interference source then restart by switching power OFF/ON</li> <li>If not resolved then consult with the supplier</li> </ul>
EPr EPr	EEPROM problem	Faulty EEPROM	Consult with the supplier
COt COt	Communication error	Communications disruption	Check the wiring

Faults which can be recovered manually and automatically			
Display	Content	Cause	Corrective action
OC-A	Over-current at acceleration	<ul style="list-style-type: none"> <li>Acceleration time too short</li> <li>The capacity of the motor exceeds the capacity of the inverter</li> <li>Short circuit between the motor coil and the case</li> <li>Short circuit between motor wiring and ground</li> <li>IGBT module damaged</li> </ul>	<ul style="list-style-type: none"> <li>Set a longer acceleration time</li> <li>Replace inverter with one that has the same rating as that of the motor</li> <li>Check the motor</li> <li>Check the wiring</li> <li>Consult with the supplier</li> </ul>
OC-A			
OC-C	Over-current at fixed speed	<ul style="list-style-type: none"> <li>Transient load change</li> <li>Transient power change</li> </ul>	<ul style="list-style-type: none"> <li>Increase the capacity of the inverter</li> <li>Install inductor on the power supply input side</li> </ul>
OC-C			
OC-d	Over-current at deceleration	The preset deceleration time is too short.	Set a longer deceleration time
OC-d			
OC-S	Over current at start	<ul style="list-style-type: none"> <li>Short circuit between the motor coil and the case</li> <li>Short circuit between motor coil and ground</li> <li>IGBT module damaged</li> </ul>	<ul style="list-style-type: none"> <li>Inspect the motor</li> <li>Inspect the wiring</li> <li>Consult with the supplier</li> </ul>
OC-S			
OV-C	Excessive Voltage during operation/ deceleration	<ul style="list-style-type: none"> <li>Deceleration time setting too short or excessive load inertia</li> <li>Power voltage varies widely (fluctuates)</li> </ul>	<ul style="list-style-type: none"> <li>Set a longer deceleration time</li> <li>Consider use of a brake resistor and/or brake module (For 400V models or 200V 5hp~15hp models)</li> <li>Consider use of a reactor at the power input side</li> </ul>
OV-C			
PF	Input phase Loss	Abnormal fluctuations in the main circuit voltage	<ul style="list-style-type: none"> <li>Check the main circuit power supply wiring.</li> <li>Check the power supply voltage</li> </ul>
PF			
LPBFT	Low pressure fault	Since feedback value of pump pressure is lower than limit of minimum flow.	<ul style="list-style-type: none"> <li>Check feedback signal is correct and with connection.</li> <li>Check if feedback value of pressure is lower than limit of minimum pressure (14-15).</li> </ul>
LPBFT			
OPBFT	High pressure fault	Since feedback value of pump pressure is lower than limit of maximum flow.	<ul style="list-style-type: none"> <li>Check feedback signal is correct.</li> <li>Check if feedback value of pressure is lower than limit of maximum pressure (14-12).</li> </ul>
OPBFT			
FBLSS	PID Feedback Signal Loss	Since proportion of loss pressure (14-19) is enabled and over high, the inverter trips to fault. Thus, feedback sensor cannot operate properly or is not installed correctly	<ul style="list-style-type: none"> <li>Check if the proportion of loss pressure (14-19) is set correctly</li> <li>Make sure the feedback sensor is installed correctly and PID feedback signal operates normally.</li> </ul>
FBLSS			

Faults which can be recovered manually but not automatically			
Display	Content	Cause	Corrective action
OC OC	Over-current during stop	Detection circuit malfunction	Consult with the supplier
OL1 OL1	Motor overload	loading too large	Consider increasing the Motor capacity
OL2 OL2	Inverter overload	Excessive Load	Consider increasing the inverter capacity
CL CL	Inverter over current: Wait 1 minute to reset .If it occurs CL or OL2 up to 4 successive times then wait 5 mins to reset	inverter over current warning: inverter current reach the level of over current protection	Check load condition and running period time.
LV-C LV-C	Voltage too low during operation	1. Power voltage too low 2. Power voltage varies widely (fluctuates)	1. Improve power quality 2. Consider adding a reactor at the power input side
OVSP OVSP	motor rotation over speed	The actual rotation speed is different to the set speed.	1. Check for excessive load 2. Check weather frequency setting signal is right or not
OH4 OH4	motor over heat error	1. If temperature detected increases above the set limit in parameter 08-13 and for the delay time set in parameter 08-12 then the display will show "OH4" (motor over heat detection), and the motor will coast to stop. 2. Motor over heat detection "OH4" can be reset when the temperature detection level is lower than the set level in parameter 【08-14 PTC reset level】 .	1.To improve the ventilation condition 2. Adjust parameter 08-15
OPErr OPErr	Operator setting error	When 09-02 set to 4, remote keypad (JN5-OP-L01) is disconnected.	1. Use "RESET" key of inverter to remove the error code 2. Set 09-02 to 0~3

## 5.1.2 Keypad Operation Error Instruction

Display	content	Cause	Corrective action
LOC	1. Parameter already Locked 2. Motor direction locked 3. Parameter password (13-07) enabled	1. Attempt to modify frequency parameter while 13-06>0. 2. Attempt to reverse direction when 11-00=1. 3. Parameter (13-07) enabled, set the correct password will show LOC.	1.Adjust 13-06 2.Adjust 11-00
LOC			
Err1	Keypad operation error	1. 1.Press ▲ or ▼ while 00-05/00-06 > 0 or running at preset speed. 2. Attempt to modify the parameter can not be modified during operation (refer to the parameter list)	1. The ▲ or ▼ is available for modifying the parameter only when 00-05/00-06=0 2. Modify the parameter in STOP mode.
Err1			
Err2	Parameter setting error	1. 00-13 is within the range of (11-08 ±11-11) OR (11-09 ±11-11) OR (11-10 ±11-11) 2. 00-12 ≤ 00-13 3. 00-05/00-06 or 10-00/10-01 set the same value 4. Modifying parameters 01-01 to 01-09 when 01-00≠7. 5. If this parameter is parameterized for both functions (AVI/PTC) at the same time ; PTC function is enabled by setting 08-10≠0; 6. Parameter password (13-07) set incorrect	1. Modify 11-08~11-10 or 11-11 2. 00-12>00-13 3. Set 00-05 / 00-06 or 10-00 / 10-01 to be different value 4. Set 01-00=7 5. PTC function source can not be the same as frequency source or PID command via AVI. 6. Please set correct password
Err2			
Err5	Modification of parameter is not available in communication	1. Control command sent during communication. 2. Attempt to modify the function 09-02~ 09-05 during communication	1. Issue enable command before communication 2. Set parameters 09-02~ 09-05 function before communication
Err5			
Err6	Communication failed	1. Wiring error 2. Communication parameter setting error. 3. Incorrect communication protocol 4. Communication ground disconnected 5. External noise	1. Check hardware and wiring 2. Check Functions(09-00~09-05). 3. CON2 needs to connect to the earth. 4. Please increase the setting value of 09-08
Err6			
Err7	Parameter conflict	1. Attempt to modify the function 13-00/13-08. 2. Voltage and current detection circuit is abnormal.	If reset is not possible, please consult with the supplier.
Err7			

### 5.1.3 Special conditions

Display	Fault	Description
StP0 STP0	Zero speed at stop	In V/f mode, STP0 comes out at less than 1.3Hz (50Hz set) or at less than 1.5Hz (60Hz set) In SLV mode, STP0 comes out at less than 1Hz
StP1 STP1	Fail to start directly On power up.	1. If the inverter is set for external terminal control mode (00-02/00-03=1) and direct start is disabled (07-04=1) 2. The inverter cannot be started and will flash STP1. 3. The run input is active at power-up, refer to descriptions of (07-04).
StP2 STP2	Keypad Stop Operated when inverter in external Control mode.	1. If the Stop key is pressed while the inverter is set to external control mode (00-02/00-03=1) then 'STP2' flashes after stop. 2. Release and re-activate the run contact to restart the inverter.
E.S. E.S.	External Rapid stop	When external rapid stop input is activated the inverter will decelerate to stop and the display will flash with E.S. message.
b.b. b.b.	External base block	When external base block input is activated the inverter stops immediately and then the display will flash with b.b. message.
PdEr PdEr	PID feedback loss	PID feedback loss is detected.
Alter ALTER	auto tuning error	other errors show up in the process of auto tuning.
OH3 OH3	motor over heat warning	If 08-10 = 3, When over temperature is detected by signal at terminal AVI increasing above the warning detection limit set in parameter 08-15, then the display will show "OH3"(motor over heat warning level) and the motor will continue to run.
LOPB LOPB	Low pressure error	<ul style="list-style-type: none"> <li>The feedback signal is not connected.</li> <li>Due to feedback value of pump pressure is lower than limit of minimum flow.</li> </ul>
HIPB HIPB	High pressure error	Due to feedback value of pump pressure is lower than limit of maximum flow.
COPUP COPUP P	Breaking error of multiple pumps communication	Communication breaking or disconnection of pump cascade control.

## 5.2 General troubleshooting

Status	Checking point	Remedy
<b>Motor runs in wrong direction</b>	Is the wiring for the output terminals correct?	Wiring must match U, V, and W terminals of the motor.
	Is the wiring for forward and reverse signals correct?	Check for correct wiring.
<b>The motor speed can not be regulated.</b>	Is the wiring for the analog frequency inputs correct?	Check for correct wiring.
	Is the setting of operation mode correct?	Check the Frequency Source set in parameters 00-05/00-06.
	Is the load too excessive?	Reduce the load.
<b>Motor running speed too high or too low</b>	Check the motor specifications (poles, voltage...) correct?	Confirm the motor specifications.
	Is the gear ratio correct?	Confirm the gear ratio.
	Is the setting of the highest output frequency correct?	Confirm the highest output frequency
<b>Motor speed varies unusually</b>	Is the load too excessive?	Reduce the load.
	Does the load vary excessively?	<ol style="list-style-type: none"> <li>1. Minimize the variation of the load.</li> <li>2. Consider increasing the capacities of the inverter and the motor.</li> </ol>
	Is the input power unstable or is there a phase loss ?	<ol style="list-style-type: none"> <li>1. Consider adding an AC reactor at the power input side if using single-phase power.</li> <li>2. Check wiring if using three-phase power</li> </ol>
<b>Motor can not run</b>	Is the power connected to the correct L1, L2, and L3 terminals? is the charging indicator lit ?	<ol style="list-style-type: none"> <li>1. Is the power applied?</li> <li>2. Turn the power OFF and then ON again.</li> <li>3. Make sure the power voltage is correct.</li> <li>4. Make sure screws are secured firmly.</li> </ol>
	Is there voltage across the output terminals T1, T2, and T3?	Turn the power OFF and then ON again.
	Is overload causing the motor to stall?	Reduce the load so the motor will run.
	Are there any abnormalities in the inverter?	See error descriptions to check wiring and correct if necessary.
	Is there a forward or reverse run command ?	
	Has the analog frequency signal been input?	<ol style="list-style-type: none"> <li>1. Is analog frequency input signal wiring correct?</li> <li>2. Is voltage of frequency input correct?</li> </ol>
	Is the operation mode setting correct?	Operate through the digital keypad

# Chapter 6 Peripherals Components

## 6.1 Reactor Specifications

Model: BL51-□□□□-HXX-X	Specification	
	Current (A)	Inductance (mH)
20P75	11.0	2.0
201P5	15.5	1.42
202P2	21.0	1.05
40P75	4.2	5.25
401P5	5.6	3.94
402P2	7.3	3.02
403P7	12	1.84
405P5	17	1.30
407P5	23	0.96
4011P	31	0.71

## 6.2 Electromagnetic Contactor and No fuse circuit breaker

Model: BL51-□□□□-HXX-X	Molded-case circuit	Magnetic contactor (MC)
20P75/201P5	50E 20A	CN-11
202P2	50E 30A	
40P75/401P5/402P2/403P7	50EC 15A	
405P5	50E 20A	
407P5	50E 30A	
4011P	50E 50A	

## 6.3 Fuse Specification

Model: BL51-□□□□-HXX-X	HP	KW	Rating
20P75	1	0.75	15A, 300VAC
201P5	2	1.5	30A, 300VAC
202P2	3	2.2	30A, 300VAC
40P75	1	0.75	5A, 600VAC
401P5	2	1.5	15A, 600VAC
402P2	3	2.2	20A, 600VAC
403P7	5	3.7	20A, 600VAC
405P5	7.5	5.5	40A, 600VAC
407P5	10	7.5	40A, 600VAC
4011P	15	11	70A, 600VAC

## 6.4 Fuse Specification(UL Model Recommended)

Model	Manufacture	Type	Rating
20P75	Bussmann	16CT/20CT	690V 16A/690V 20A
201P5	Bussmann	30FE	690V 30A
202P2	Bussmann	50FE	690V 50A
40P75	Bussmann	80/100 FE	690V 80/690V100A
401P5	Bussmann	10CT	690V 10A
402P2	Bussmann	16CT	690V 16A
403P7	Bussmann	20CT	690V 20A
405P5	Bussmann	25ET	690V 25A
407P5	Bussmann	40FE	690V 40A
4011P	Bussmann	50ET	690V 50A

## 6.5 Braking Resistor

Model: BL51-□□□□-HXX-X	(HP)	(KW)	Braking resistor		Braking torque 10 % ED
			(W)	(Ω)	
40P75	1	0.75	150	750	126
401P5	2	1.5	150	400	119
402P2	3	2.2	260	250	126
403P7	5	3.5	400	150	126
405P5	7.5	5.5	600	120	102
407P5	10	7.5	800	100	99
4011P	15	11	1600	50	126

※**Note:** Braking resistor :  $W = (V_{pnb} * V_{pnb}) * ED\% / R_{min}$

1. W: The power consumption of braking action
2. V<sub>pnb</sub>: The voltage of braking action (220V=380VDC, 440V=760VDC)
3. ED%: The effective period of braking action
4. R<sub>min</sub>: braking resistor minimum value (ohms)

# ALL INDIA SERVICE NETWORK

- Regional Offices
- 🏭 Works
- ✂ Service Centre: Drives
- ✂ Service Centre: Servo Motors

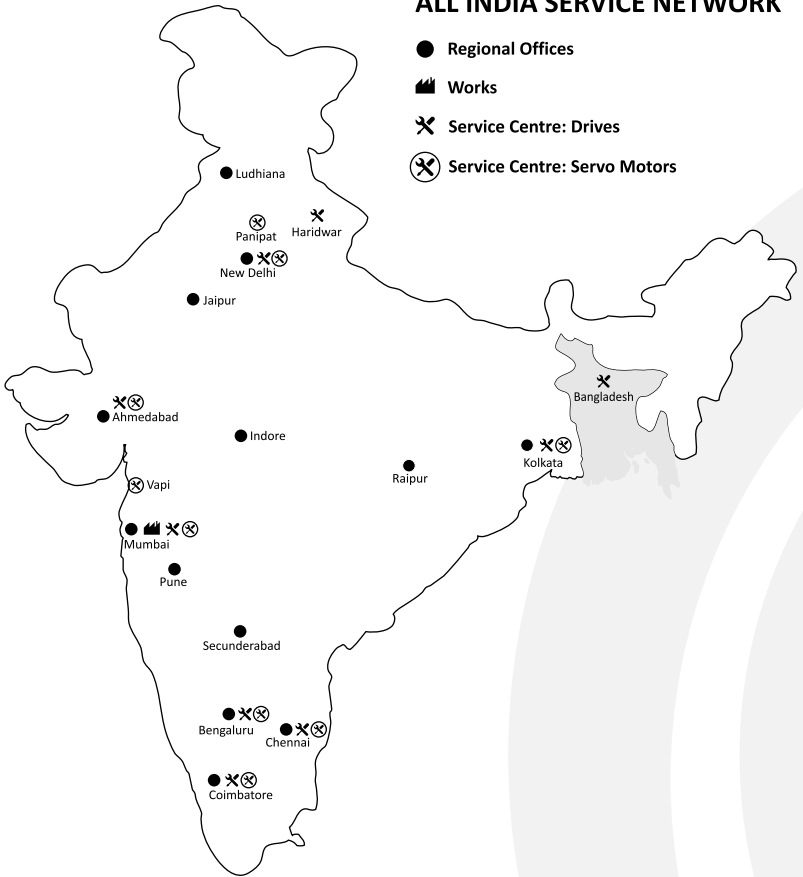

**BB ServiceLINE™**  
Customer Service Helpdesk for Industrial Systems

+91 22 - 2763 7290 | [serviceline@bharatbijlee.com](mailto:serviceline@bharatbijlee.com)



## Bharat Bijlee Drives & Automation

Mobile App for Troubleshooting and Maintenance of Drives & Servo Motors  
Download for free from Google Play Store



**REGISTERED OFFICE**  
Electric Mansion, 6th Floor,  
Appasaheb Marathe Marg,  
Prabhadevi, Mumbai 400 025  
T: +91 22 2430 6237 / 6375  
E: [info@bharatbijlee.com](mailto:info@bharatbijlee.com)  
CIN: L31300MH1946PLC005017

**WORKS**  
No. 2, MIDC Thane-Belapur Road, Airoli,  
Navi Mumbai 400 708  
T: +91 22 2763 7200 / +91 22 2760 0401  
E: [drivesales@bharatbijlee.com](mailto:drivesales@bharatbijlee.com)  
[www.bharatbijlee.com](http://www.bharatbijlee.com)