

Powered by Trust™

 Bharat Bijlee

BBVERT **BL50** Series



USER MANUAL

Chapter 1 | Safety

1.1 General Safety

Safety Information :

Caution : Identifies information about practices or circumstances that can cause personal injury or equipment damage.

Warning : Identifies information about practices or circumstances that can cause an explosion in a hazardous environment, which may lead to personal injury or death, property damage, or economic loss.

1.1.1 Usage

Caution
<ul style="list-style-type: none">■ The drive is used to control the speed of 3 phase synchronous and asynchronous motors, which must not be used for single phase or other purposes. Failure to comply could cause drive damage or serious injury by fire.■ The drive must not be used in any medical equipment in which human life may involve.■ The drive is manufactured according to strict quality control standard. However, bypass the safety protection in case the drive failure causes death or serious injury.

1.1.2 Receiving

Warning
<ul style="list-style-type: none">■ Do not install damaged drive or any drive without complete components inside. Failure to comply could result in accident.■ The product must be complete, including packaging, instruction and accessories.■ New or updated information, please refer to the following link : https://www.bharatbijlee.com/drives-automation/

1.1.3 Installation

Warning
<ul style="list-style-type: none">■ Carry the drive by the bottom as carrying by the front cover may cause injury and damage from the main body of the drive falling.■ Attach the drive to metal or other nonflammable materials. Keep away from heat and flammable items.

- A control panel must have cooling fans, air vents and room for ventilation when the drive is installed inside.
- The mounting surface in contact with the heat sink should be made of metal, which provides good thermal conductivity and prevents flammability
- Please check the dust-proof and moisture-proof conditions to avoid the external environment affecting the inverter function.

1.1.4 Wiring

Caution

- Allow only qualified electrical engineers to install the drive. Failure to comply could cause electrical shocks to personnel or damage to the drive.
- Ensure the power supply is off when connecting. Failure to comply could cause electrical shocks.
- Ensure the ground terminal PE is properly wired. Failure to comply could cause electrical shocks from the drive cover. Therefore ground the drive and motor for personnel safety.
- Do not touch the main circuit terminal. Keep the main circuit off drive cover to avoid electrical shocks

Warning

- Do not connect three-phase power supply to terminals U, V and W. Failure to comply could damage the drive.
- An output reactor is recommended when the cable connecting between the drive and motor is over 100 meters. Failure to comply could result in drive damage with over current caused by over-distributed capacitance.
- Never connect the output terminals to capacitors or unapproved LC/RC filters. Failure to comply could damage the drive components.
- Separate the drive main circuit cables and control circuit cables. Failure to comply could cause interference to the control signals
- Ensure the phase of power supply and rated voltage match the label on the drive. Failure to comply could drive damage.

1.1.5 Operation

Caution
<ul style="list-style-type: none">■ Connect the power after completion of wiring and closing the front cover. Opening the front cover when the power is on could cause an electrical shock.■ Keep other personnel off the equipment when setting the drive fault restart and momentary power loss restart functions. Failure to comply could cause damage to the personnel and equipment.■ Once the drive is powered, the terminals are live even when drive is not in operation. Touching the terminals could cause electrical shocks.■ Cancel run command before resetting the alarm and fault. Failure to comply could cause physical injury.
Warning
<ul style="list-style-type: none">■ Do not start or stop the drive by connection or disconnection the power supply. Failure to comply could cause drive damage.■ Ensure the motor and equipment is in proper use before operation. Failure to; comply could damage the equipment.■ The temperature of the braking resistor and heatsink could be very high during operation. Do not touch it or it could result in scald.■ For lift applications, please install mechanical brakes.■ Adjust a few parameters only if necessary as the defaults are optimum settings for most of applications. Editing parameters indiscriminately could cause equipment abnormal operation.■ Interlock the electricity supply with AC drive supply when both are available to a motor.

1.1.6 Maintenance

Caution
<ul style="list-style-type: none">■ Do not touch the main circuit of the drive when power is on. Failure to comply could cause electrical shocks.■ Disconnect the power supply before opening the front cover of the drive.■ Maintain the drive only when the CHARGE indicator light is off or 5 minutes after turning off power supply, so as to avoid charged capacitors causing physical injury.■ Allow only qualified electric engineers and electrician to maintain, repair and replace the AC drive modules.

Warning

- The release of breaker on the AC drive primary side could be caused by incorrect wiring, short circuit and damaged drive components. Investigate and remove the problem before reconnecting the breaker.
- Do not use a megger (insulation resistor) to test the drive control circuit. Failure to comply could cause drive damage.

Notice:

All the instruction photographs and diagrams of opened drive in this manual are only for illustration. Do not attempt to operate any AC drives with the cover opened.

1.2 Warning Label

The warning label is on the side of the drive. Please read it carefully and follow the instructions.

- Read the user manual before operation.
- Risk of electrical shock. Shut off main power and wait for 5 minutes before servicing.
- Hot surface. Risk of burn.

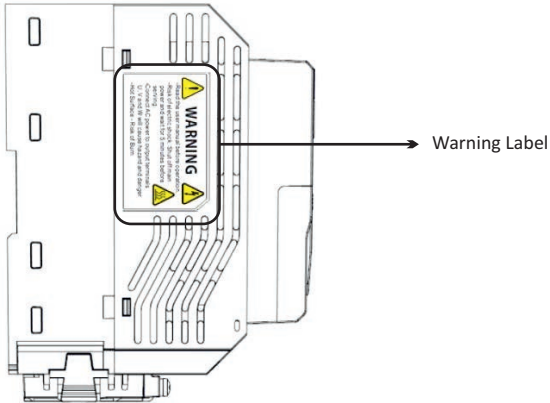

1.3 AC Drive Application Precautions

1.3.1 AC Drive Selection

1.3.1.1 Drive Capacity

Before driving motors, ensure the motor rated current is lower than the drive rated output. In addition, when a single AC drive is driving more than 1 motor in parallel, make sure the drive capacity is higher than 110% of total motor rated current.

1.3.1.2 Starting Torque

The motor characteristics at start and during acceleration are limited by the drive overcurrent. If higher starting torque is needed, use a higher rating drive or increase capacity of both motor and drive.

1.3.1.3 Emergency Stop

When a drive fault occurs, protection function will be automatically triggered to shut off the output but the motor may not stop immediately. Therefore please install mechanical brake if immediate stop is necessary.

1.3.1 Settings

1.3.2.1 Upper Limits

The maximum output frequency of the drive is 400Hz. If the upper limit is set incorrectly, the motor will run at higher than its rated speed and cause danger. Please set the limit of output frequency in Frequency Upper Limit parameter. The default setting of the rated output frequency is 60Hz.

1.3.2.2 DC Braking

Excessive DC braking current and duration could cause motor overheat.

1.3.2.3 Acceleration/Deceleration Time (Acc./Dec. Time)

Acceleration and deceleration time is determined by the motor torque, load torque and load inertia. Set a longer Acc./Dec. time after Stall Prevention function is triggered. In addition, the acceleration and deceleration time will be extended depending on the Stall Prevention duration. If faster acceleration and deceleration are required, install proper braking options or use a higher rating motor and AC drive.

1.3.3 General Handling

1.3.3.1 Wiring

Connecting power supply to output terminals U/T1, V/T2 and W/T3 will damage the drive. Check all the connections and wiring sequence before turning on the power. Failure to comply could cause drive damage.

1.3.3.2 Maintenance

Capacitors in the drive may still be charged for a short time after shutting off the power. Wait for the amount of time specified on the drive before any maintenance. Failure to comply could cause electrical shocks to personnel. Besides, do not touch the heatsink which can be very hot during operation. Replace the cooling fan only when the heatsink has cooled down after shutting off the power. In addition, when a synchronous motor is coasting to stop, it regenerates voltage to keep the drive terminals live even when the drive power is off. Wait until the motor is fully stopped before drive maintenance. Failure to comply could cause electrical shocks to personnel.

1.3.3.3 Wiring Tools

Use only the tools suggested by the terminal supplier during drive maintenance.

1.3.3.4 Transportation and installation

Do not expose the drive to the environment containing the halogens or DOP gas during transportation or installation.

1.4 Warranty

1.4.1 Warranty Period

Contact Bharat Bijlee/Drive Sales Partner for details.

1.4.2 Warranty Restrictions

Warranty is not applicable when the drive is not properly used according to the manual regardless warranty period.

Chapter 2 | Product

2.1 Component Names

This section describes the structure of BL50. (The fan and fan cover are only for force air-cooled type.)

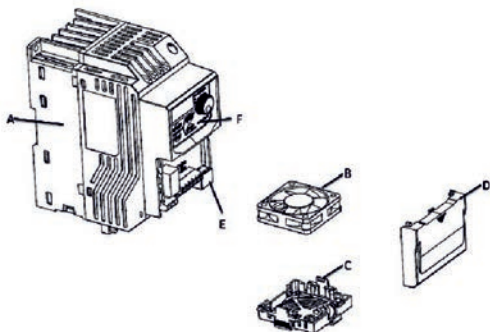

- A - Heatsink
- B - Cooling fan
- C - Fan guard

- D - Conduit bracket
- E - RJ45 port
- F - Keypad





2.2 Receiving Checklist

Check the following when receiving the drive :

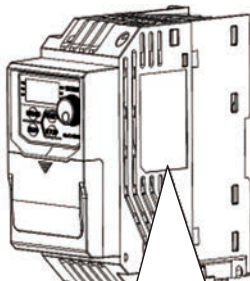
1.	Is the packaging box in good condition? Any damage or damp? If so, contact the distributor or local BBL representative.
2.	Is the model label on the box same as what you purchased? If not, contact the distributor or local BBL representative.
3.	After opening the box, is there any damp mark inside the box? Any damage or crack on the drive enclosure? If so, contact the distributor or local BBL representative.
4.	Does the drive nameplate show the same model number as the carton label? If not, contact the distributor or local BBL representative.

2.3 Nameplate



Model number	→	MODEL : BL50-403P7-H3F-E20
Input power supply	→	INPUT : AC 3PH, 380-480 V, 12.9A
Output power supply	→	OUTPUT : AC 3PH, 0...Uin, 8.2A, 0 - 599Hz
Applicable motor rating	→	AC MOT : 5kW
		SERIAL NO. : 12H3P7433D19330041
		Customer service contact +91 22-27637290 serviceline@bharatbijlee.com
		 Bharat Bijlee   

2.4 Model Number Definition

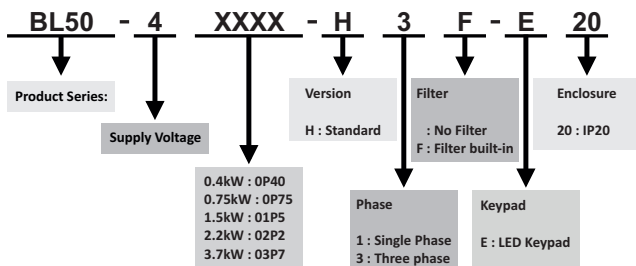

2.5 Power Ratings

200V Class Single Phase						
Model No.	BL50	0P2	0P4	0P75	01P5	02P2
Max. Motor Capacity	HP	0.25	0.5	1	2	3
	kW	0.2	0.4	0.75	1.5	2.2
Rated Input	Voltage (V) / Frequency (Hz)	Single Phases, 200 ~220 V, -15% ~ +20% , 50/60Hz				
	Current(A)	3.6	7.4	13.5	24	33
Rated Output	Current(A)	1.6	2.5	4.2	7.5	11
	Output Frequency (Hz)	0 to 400 Hz				
	Carrier Frequency (kHz)	2 to 12kHz				
Cooling Method	Fanless			Fan		
Frame	1			2		
Weight	1.1kg			1.6kg		

200V Class Three Phase							
Model No.	BL50	0P2	0P4	0P75	01P5	02P2	03P7
Max. Motor Capacity	HP	0.25	0.5	1	2	3	5
	kW	0.2	0.4	0.75	1.5	2.2	3.7
Rated Input	Voltage (V) / Frequency (Hz)	Three Phases, 200 ~220 V, -15% ~ +20% , 50/60Hz					
	Current(A)	2.2	3.7	6.6	10.5	14.8	21.5
Rated Output	Current(A)	1.6	2.5	4.2	7.5	11	17
	Output Frequency (Hz)	0 to 400 Hz					
	Carrier Frequency (kHz)	2 to 12kHz					
Cooling Method	Fanless			Fan			
Frame	1			2			
Weight	1.1kg			1.6kg			

400V Class Three Phase						
Model No.	BL50	0P4	0P75	01P5	02P2	03P7
Max. Motor Capacity	HP	0.5	1	2	3	5
	kW	0.4	0.75	1.5	2.2	3.7
Rated Input	Voltage (V) / Frequency (Hz)	Three Phases, 380 ~480 V, -15% ~ +20% , 50/60Hz				
	Current(A)	2.7	4.4	6.7	9.3	12.9
Rated Output	Current(A)	1.5	2.5	4.2	5.5	8.2
	Output Frequency (Hz)	0 to 400 Hz				
	Carrier Frequency (kHz)	2 to 12kHz				
Cooling Method		Fanless		Fan		
Frame		1			2	
Weight		1.1kg			1.6kg	

2.6 Common Specifications

Item		Specification
Control Characteristic	Control Method	V/F Control, Sensorless Voltage Vector Control (SVVC)
	Output Frequency	0~400 Hz
	Frequency Accuracy	Digital Input: Within $\pm 0.01\%$ of the max. output frequency
		Analog Input: Within $\pm 0.1\%$ of max. output frequency (-10°C to $+50^{\circ}\text{C}$)
	Frequency Setting Resolution	Digital Input : 0.01Hz
		Analog Output: 1/1000 of max. frequency
	Starting Torque	150% / 3Hz (V/F)
		150% / 1Hz (SVVC)
	Speed Control Range	1: 40 (V/F)
		1:100 (SVVC)
	Acc/Dec Time	0.0 to 3600.0
Braking Torque	Approx. 20%	
V/F Pattern	15 fixed and 1 programmable	
Overload Capacity	150% for 1 min. in every 10 min.	

Control Characteristic	Parameter Function	Over Torque / Under Torque Detecion, Multi-Speed Operation, Acc./Dec. Switching, S-curve Acc./Dec., 3-Wire Sequence Control, Auto Tuning, Cooling Fan ON/OFF Function, Slip Compensation, Torque Compensation, Frequency Jump, Frequency Command Upper and Lower Limit Setting, DC Braking at Start / Stop, PID Control including Pause Function, Energy Saving Mode, Fault Reset, Traverse, Etc.
Operating Environment	Area of Use	Indoor without corrosive gas / liquid or flammable gas / liquid / oil mist / dust
	Ambient Temperature	-10 ⁰ C to +50 ⁰ C, below 90% RH without froze or condensation
	Storage Temperature	-20 ⁰ C to +60 ⁰ C
	Altitude	Up to 1000 meters
	Shock	Below 9.8 m/s ² (10 to 20 Hz) , below 5.9 m/s ² (20 to 55 Hz)
	Enclosure	IP20
I/O	Analog Input (AI)	1 point (AI : 0 to 5V, 0 to 10V (12 bits) 0 or 4 to 20mA (11 bits))
	Digital Input (DI)	6 points
	Analog Output (AO)	1 point (FM : 0 to 10V (10 bits))
	Digital Output (DO)	0
	Relay Output (RO)	1 point
Communications		Modbus (RS-485 port)
Option Card		Profibus-DP, CANopen, Device Net
Short-Circuit Current		The drive is suitable for use in a circuit capable of delivering not more than 5,000 rms symmetrical amperes, 480 Volts Maximum.

*1. Results tested in labs

2.7 Product Dimensions

Frame Size 1

200V:

BL50-20P20-H1F-E20, BL50-20P40-H1F-E20, BL50-20P75-H1F-E20, BL50-20P20-H3-E20, BL50-20P40-H3-E20, BL50-20P75-H3-E20, BL50-201P5-H3-E20

400V:

BL50-40P40-H3F-E20, BL50-40P75-H3F-E20, BL50-401P5-H3F-E20

Frame Size 2

200V:

BL50-201P5-H1F-E20, BL50-202P2-H1F-E20, BL50-202P2-H3-E20, BL50-203P7-H3-E20

400V:

BL50-402P2-H3F-E20, BL50-403P7-H3F-E20

Frame 1

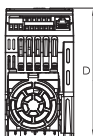
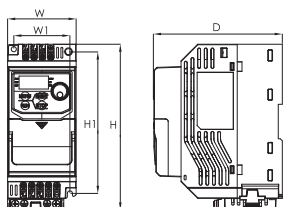

Frame 2

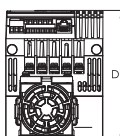
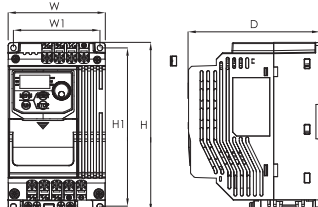

Dimensions in mm [inch]

Series	Frame	W	W1	H	H1	D	S1	Φ
BL50	1	72 [2.83]	59 [2.32]	174.2 [6.86]	151.6 [5.97]	135.6 [5.34]	5.4 [0.21]	5.4 [0.21]
	2	100 [3.94]	89 [3.50]	174.2 [6.86]	162.6 [6.41]	135.6 [5.34]	5.8 [0.23]	5.4 [0.21]

2.8 Accessories

2.8.1 Accessories

BL50 Series Accessories		
Name	Model Name	Description
Copy Unit	BL50-CU	Allows parameter uploads/downloads and comparison
Braking Unit	BL50-DBU-2 □□□	Connects AC drive terminal DC+, DC- to significantly improve braking. Please ensure braking resistor is properly installed. (□□□ indicates 1D5 or 3D7 model)
	BL50-DBU-4 1D5	
Remote keypad	BL50-RK	Connects remote keypad for remote setting and monitoring

Chapter 3 | Drive Installation

3.1 Installation Environment

To ensure the optimum drive performance, install the AC drive in a proper environment specified below.

Environment	Conditions
Area of Use	Indoors
Ambient Temperature	<ul style="list-style-type: none">● -10°C to +50°C (IP20 enclosure)● Do not install the drive in environments with wide temperature fluctuations so as to ensure the drive reliability.● When the drive is installed in an enclosure cabinet, make sure the cooling Temperature works properly to keep the temperature within the specified levels.● Do not allow the drive to freeze.● When drives are installed side-by-side in a cabinet, follow the instruction illustrated in Figure 3.2 to ensure the air flow.
Humidity	<ul style="list-style-type: none">● Under 90% RH● Free of condensation
Storage Temperature	-20°C to +60°C
Surrounding Area	<ul style="list-style-type: none">● Free from water, oil, metal shavings or other foreign materials.● Free from flammable materials (e.g., wood)● Free from harmful gases and liquids● Free from direct sunlight● Free from oil mist, corrosive gas, flammable gas or dust.● Free from radioactive material● Green Class 2 or above
Altitude	Up to 1000 m without derating. Up to 2000 meters with 1% rated current derated for every 100 m counted from 1000 m.
Vibration	<ul style="list-style-type: none">● 10 to 20 Hz at 9.8 m/s²● 20 to 55 Hz at 5.9 m/s²
Enclosure	IP20

3.2 Installation Direction and Spacing

3.2.1 Installation Direction

Install the AC drive upright for better cooling.

OK

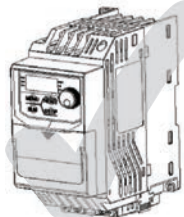

A. Upright installation

NG

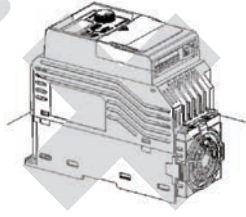

B. Horizontal installation

NG

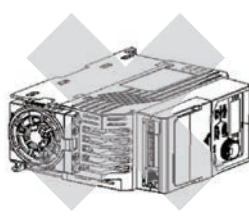

C. Transverse installation

Figure 3.2.1 Installation Direction

3.2.2 Installation Spacing

Install the AC drive as illustrated below to ensure the required space for airflow and wiring.

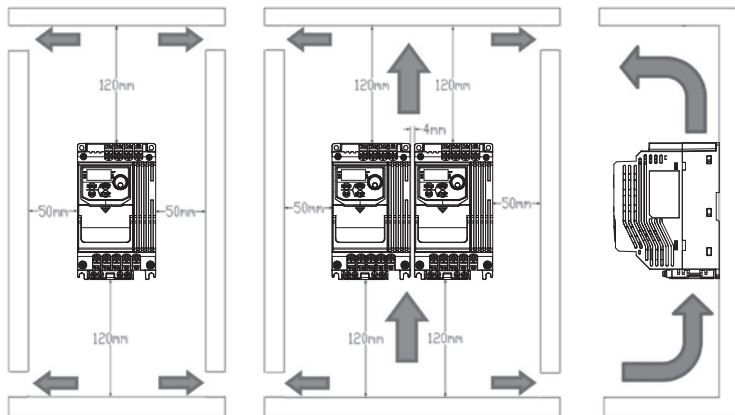
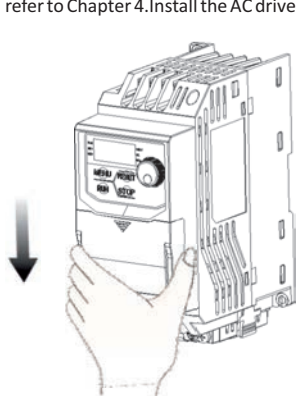

Figure 3.2.2 Installation Spacing Single

Note : When installing drives of different sizes, align the tops of the drives for easier cooling fan replacement.

3.3 Keypad and Terminal Cover Installation

It is not necessary to remove the keypad before wiring. You just need to loosen the terminal cover screw and remove the terminal cover. After wiring, affix the terminal cover back in position and tighten the screw. For wiring instructions and screw tightening torque please refer to Chapter 4. Install the AC drive upright for better cooling.



Step 1 : Slide the terminal cover down

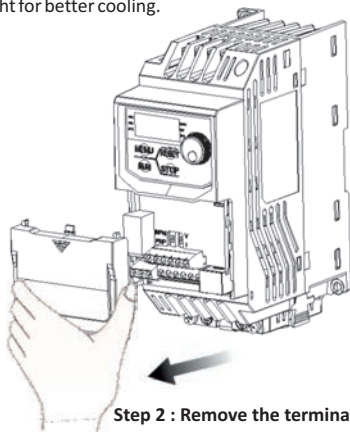

Step 2 : Remove the terminal cover

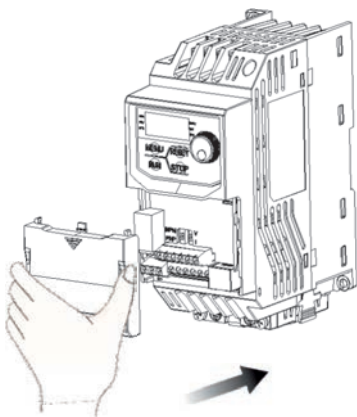

Step 3 : Affix the terminal cover after wiring

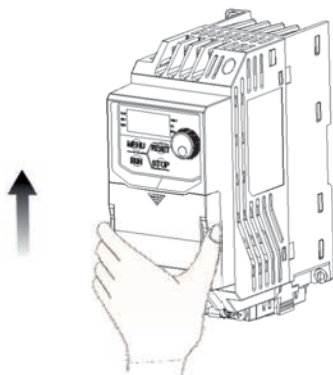

Step 4 : Slide the terminal up

3.4 Wiring Protection

3.4.1 Drive and Input Cable Protection for Short-Circuit Situations

Protect the drive and input power cable by using fuse in case potential short-circuit situations cause overheating. Please refer to the following figure for proper wiring.

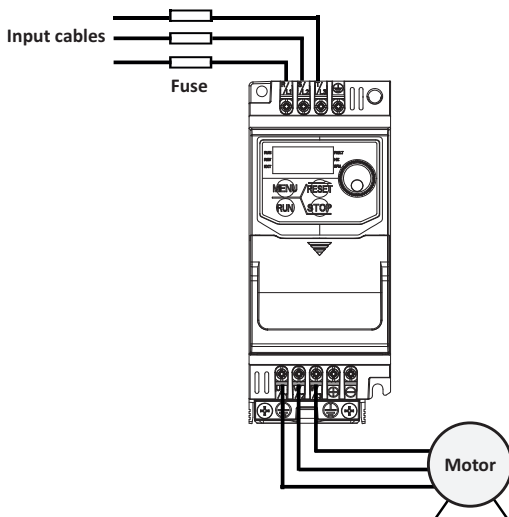

Figure 3.4.1 Fuse Installation

3.4.2 Motors and Output Cable Protection for Short-Circuit Situations

If the output cables are properly selected according to the drive rated current, the drive itself is fully capable of protecting the motor and output cables in case of short-circuit situations.

Note: If a single drive runs more than 1 motor, a separate thermal overload switch or a circuit breaker is required.

Chapter 4 | Wiring

4.1 Wiring Safety

Caution

- Turn off all the power to the equipment before wiring. Wiring during power on could cause electrical shocks to personnel.
- Allow only qualified personnel for installation, wiring, repairing and parts replacement.
- Capacitors in the drive may still be charged for a short time after shutting off the power. Wait for the amount of time specified on the drive before any maintenance.
- Never touch input or output power cables. Do not connect any circuit to drive enclosure.

Warning

- Properly connect the motor ground terminal. Contacts between the motor ground terminal and motor enclosure could cause electrical shocks or a fire.
- Ensure terminal screws are all tightened. Loose connection to the main circuit could cause overheat or a fire.
- Verify if the rated voltage of the drive matches the voltage of the incoming power supply before applying power.
- Perform all wiring as specified in the wiring diagrams provided when installing braking unit.
Failure to comply could result in drive, braking unit or resistor damage on fire.
- Do not disconnect the motor from the drive while the drive is outputting voltage.
- Do not use unshielded cable for control circuit wiring. Failure to comply could cause abnormal operation of drive.
- Use shielded twisted-pair cables and connect the shield to ground terminal of the drive.
- Do not modify the drive circuits. Failure to comply could cause drive damage.
- Ensure all connections are correct after connecting the drive with other devices.

4.2 Main Circuit

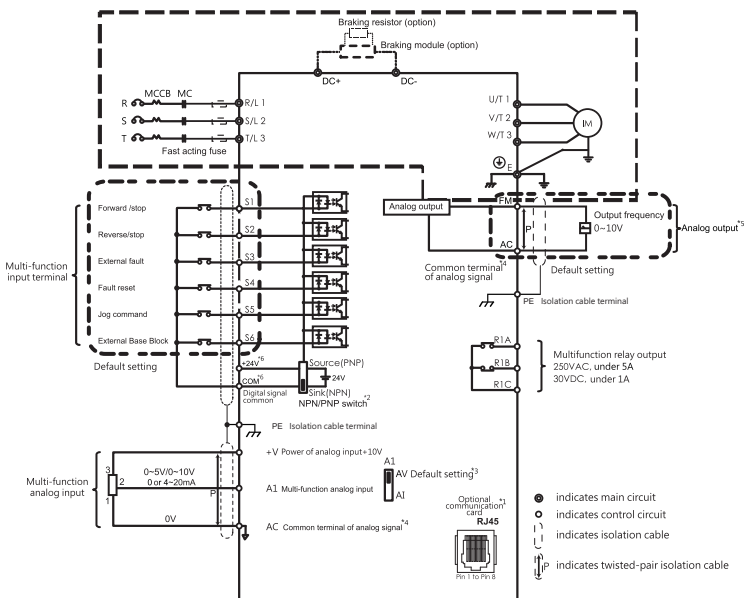

■ Ensure the Stall Prevention function is off when using a braking unit

4.2.1 Main Circuit Terminal

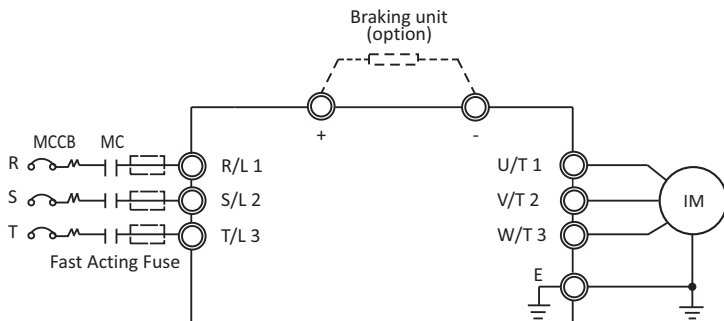

Table 4.2.1 Main Circuit Terminals

Terminal Name	Terminal Description
R/L1, S/L2, T/L3	Power input terminal
U/T1, V/T2, W/T3	Power output terminal
+, -	Braking unit terminal. Select option as per the specifications.
E	Ground terminal

4.2.2 Main Circuit Wiring

4.2.2.1 Power Input Terminal

- Install a molded case circuit breaker (MCCB) between three phase AC input power and main circuit terminals R/L1, S/L2 and T/L3. A magnetic contactor (MC) in series connection is also suggested so as to shut off the power by drive protection functions. Install a R-C varistor on both ends of the MC.
- Ensure main circuit terminal screws are tightened to avoid vibration loosening the screws which could cause electric sparks.

4.2.2.2 Power Output Terminal

- When connecting a noise filter at AC drive output terminals U/T1, V/T2 and W/T3, always use an inductive L-filter. Do not install any power capacitor, L-C or R-C filter.
- Connect AC drive output terminals U/T1, V/T2 and W/T3 to motor input terminals U, V and W respectively. Ensure the motor and drive terminals are in same phase sequence or the motor will rotate reversely.

- Do not connect power cable to output terminals of the drive. Failure to comply could causedrive damage and a fire.

4.2.2.3 Braking Unit Terminal :

- If the drive is used in a high-frequency or heavy duty application which requires frequent braking or shorter deceleration time, install an optional braking unit to increase the braking torque.

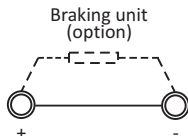

- Please refer to the wiring diagram when installing braking unit.

4.2.2.4 Ground Terminal

- Use grounding cables of dimensions regulated by electrical equipment standard. Shrink wiring distance to prevent leakage current resulting unstable electrical potential at the terminal distant from grounding terminal.
- Do not use share the same grounding cable with welding machines or any device requiring large current. Failure to comply could cause drive or equipment malfunction.
- Do not wind the grounding cable when multiple drives are installed. Failure to comply could cause drive or equipment malfunction.
- Ensure the neutral of the input side and drive terminal " \oplus " are grounded according to the local electrician regulations. 3WYE (e.g. TN and TT) system are suggested for the drive primary side.

4.2.2.5 Jumper

- BL50 complies with the European LVD standard EN 61800-5-1 (2007) reducing the touch current to below 10mA DC under testing condition regulated by IEC 60990 (1999).
- Follow the instructions below to remove the jumper if an even lower current leakage to a even lower level.
- Removing the jumper may increase the signal interference.

1. Front right corner of the machine, remove the screw using a screwdriver.

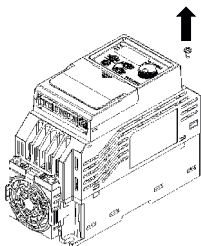

2. Remove the top right corner of the right side of the ground blade screw and save.

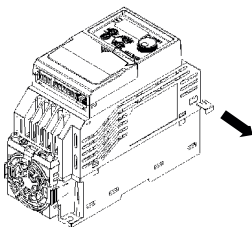

4.2.2 Main Circuit Cable Size and Tightening Torque

Select the cables and crimp terminals according to Table 4.2.2.

1. The recommended cables (copper conductors) are 600 V vinyl-sheathed cables which has continuous temperature tolerance up to 75°C with ambient temperature tolerance up to 40°C and wiring distance up to 100 meters.
2. Terminal + and - are only for connecting DC reactor and braking resistor options. Do not connect it to other devices.
3. Consider the amount of voltage drop when selecting cable sizes. Increase the cable size when the voltage drop exceeds 2% of the motor rated voltage. The amount of voltage drop can be calculated using the following formula :

Line drop voltage (V) = 3 x cable resistance (Ω /km) x cable length (m) x current (A) x 10^{-3}

Table 4.2.2 Cable Size and Tightening Torque (Three-phase 400V & single phase 200V)

Drive Frame	Terminal	USA		Europe & Asia		Terminal Screw Thread	kgf-cm (in-lbf)
		Suggested Cable Size AWG, kcmil	Applicable Cable Size AWG, kcmil	Suggested Cable Size mm ²	Applicable Cable Size mm ²		
Frame 1	R, S, T, U, V, W, PE	12	12 to 18	3.3	3.3 to 0.8	M3	16.1 (14)
Frame 2	R, S, T, U, V, W, PE	8	8 to 18	8.4	8.4 to 0.8	M4	18.3 (15.9)

4.3 Control Circuit

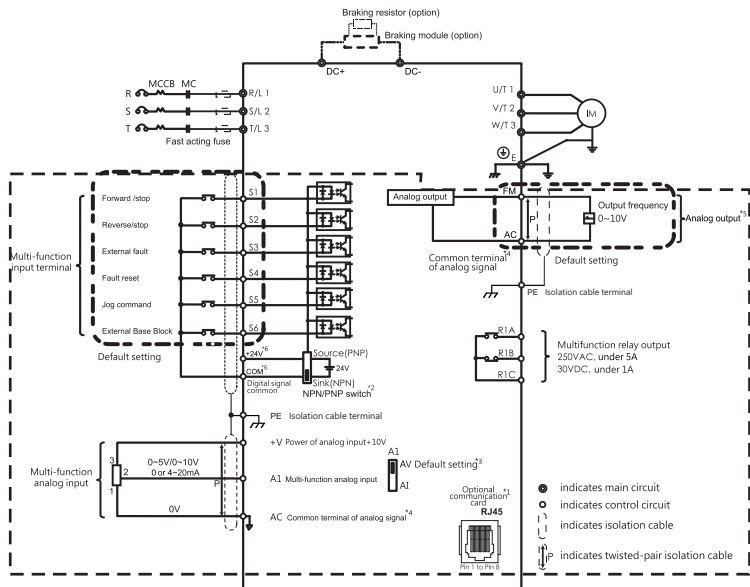

- RJ45 port can be connected to the built-in RS-485 communication or option communication cards (options cards are under development)
- Multi-function analog input S1 to S6 can be switched between Sink (NPN) mode and Source (PNP) mode. The default setting is NPN mode.
- DIP switch A1 is used to set the analog input type as voltage or current.
- AC (Analog Common) is the common terminal of analog signal.
- Analog output is used to connect a frequency meter, current meter, voltage meter and power meter.
- +V is the input terminal for auxiliary power.

4.3.1 Control Circuit Terminals

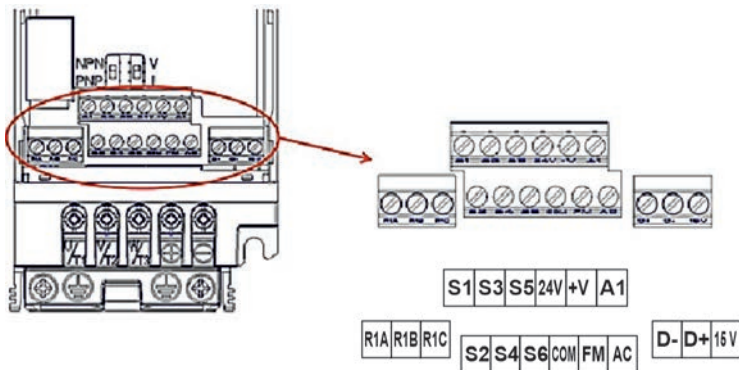

4.3.1.1 Input Terminals

Table 4.3.1.1 Control Circuit Input Terminal

Terminal Type	Terminal Code	Terminal Name	Terminal Description
Multi-Function Digital Inputs	S1	Digital input terminal 1 (forward/stop)	Photocoupler, 24 V, 8 mA. Use NPN/PNP switch to select multi-function digital input type. The default is NPN mode.
	S2	Digital input terminal 2 (reverse/stop)	
	S3	Digital input terminal 3 (external fault 1)	
	S4	Digital input terminal 4 (fault reset)	
	S5	Digital input terminal 5 (Jog)	
	S6	Digital input terminal 6 (Baseblock)	
	24V	+24V auxiliary power terminal for analog input	
COM	Digital input common terminal for NPN/PNP mode switch. Select the mode correctly when connecting.		
Multi-Function Analog Inputs	+V	Auxiliary power terminal +10V	Analog input power+10V
	A1	Analog input terminal 1 (main frequency command)	Voltage input: 0 to 5V or 0 to 10V Impedance value: 32K Ω Current input: 0 or 4 to 20mA Impedance value: 250 Ω

Multi-Function Analog Inputs	PE	Ground terminal	The ground terminal for control signals to avoid interference. Use shielded cables only.
	AC	Common terminal for analog signals	

4.3.1.2 Output Terminals

Table 4.3.1.2 Control Circuit Output Terminals

Terminal Type	Terminal Code	Terminal Name	Terminal Description
Multi-Function Relay Output	R1A	Relay 1 normal open	Relay output : DC 30 V, 1 A AC 250 V, 5 A
	R1B	Relay 1 normal closed	
	R1C	Relay 1 common	
Multi-Function Analog Output	FM	Programmable analog output terminal (output frequency)	Voltage Output : 0 to 10V Impedance value : 20KΩ
	AC	Analog common terminal	

<1> Do not assign frequent switching functions such as ON/OFF to terminals R, which may shorten the relay terminal life.

4.3.2 Control Circuit Wiring

The applicable functions in parameter Group E can be assigned to multi-function digital inputs (S1 to S6), multi-function relay outputs (R1), multi-function analog input (A1) and multi-function analog output (FM). The default settings are listed in Figure 4.3.1.1 and Figure 4.3.1.2.

- For safety, always check the emergency stop operation after wiring. Emergency stop circuit is necessary to stop the drive immediately in a safe manner to prevent any injuries.
- Do not remove the drive covers or touch the circuit boards when the power is on. Failure to comply could cause electrical shocks to personnel.
- Separate control circuit wiring from main circuit wiring and other power lines. Failure to comply could cause drive malfunction.
- Insulate shielded cable with tape to avoid contact with equipment and other signal lines. Improper insulation could cause drive or equipment malfunction.
- Always use shielded twisted-pair cables to prevent drive and equipment malfunction cause by electrical interference.
- Ground the shield to the ground terminal of drive. Failure to comply could cause erroneous operation or damage to the drive and equipment. Wire ground terminal and main circuit terminals before wiring control circuit terminals.

4.3.3 Control Circuit Cable Size and Tightening Torque

Select the cable according to Table 4.3.3.1. Use crimp ferrules on the cable ends for simpler and more reliable wiring.

Table 4.3.3.1 Cable Size and Tightening Torque

Terminal	Bare Cable		Ferrule-Type Terminal		kgf-cm (in-lbf)	Cable Type
	Suggested Size mm ² (AWG)	Applicable Size mm ² (AWG)	Suggested Size mm ² (AWG)	Applicable Size mm ² (AWG)		
S1, S2, S3, S4, S5, S6, COM, 24V, +V,A1, AC, FM, PE D+,MP,D-DC,PE,D1	0.26 ~ 1.31 (23 ~ 16)	0.13 ~ 2.08 (26 ~ 14)	0.41 ~ 1 (17 ~ 21)	1.3 ~ 0.3 (22 ~ 16)	5.1-8.1 (4.4-7in-lbf)	Shielded cable, etc.
R1A, R1B, R1C	0.26 ~ 1.65 (23 ~ 15)	0.13 ~ 3.31 (26 ~ 12)	3.31 (12)	0.13 ~ 3.31 (26~12)	5.1-8.1 (4.4-7in-lbf)	Shielded cable, etc.

4.3.4 Ferrule-Type Terminals

Always use ferrule-type terminals with insulated sleeves. Refer to Table 4.3.3.2. for dimensions. In addition, crimping tool CRIMPFOXZA-3 manufactured by Phoenix Contact is recommended.

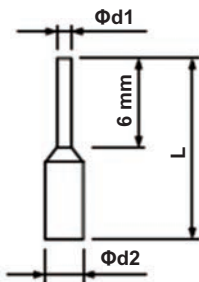

Table 4.3.3.2 Ferrule-Type Terminal Models and Sizes

Cable Size mm ² (AWG)	Type	L (mm)	d1 (mm)	d2 (mm)	Manufacturer
0.25 (24)	AI 0.25-6YE	10.5	0.8	2	Phoenix Contact
0.34 (22)	AI 0.34-6TQ	10.5	0.8	2	Phoenix Contact
0.5 (20)	AI 0.56-WH	14	1.1	2.5	Phoenix Contact

4.4 I/O Connections

4.4.1 NPN and PNP Mode Selection

Use Sink/Source DIP switch on the control board to set NPN/PNP (Sink/ Source) mode for multi-function digital inputs S1 to S6. (Default: NPN mode)

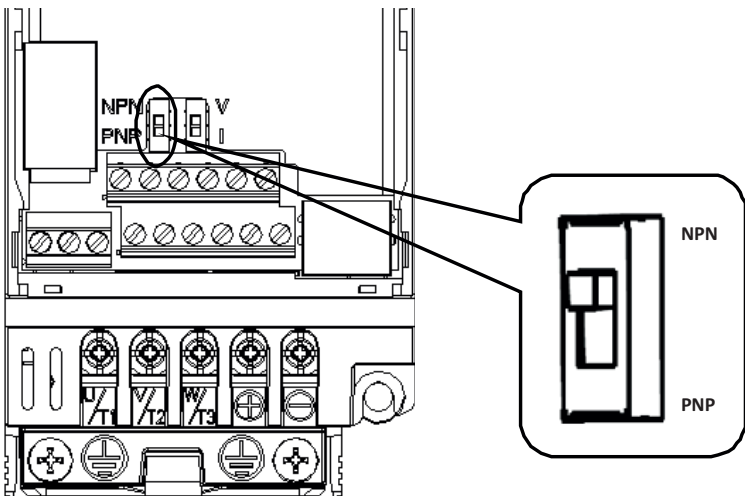

Figure 4.4.1 NPN/PNP (Sink/Source) DIP Switch

4.4.2 Terminal A1 Voltage/Current Input Selection

Select voltage or current input at terminal A1

- To select current as the input type, set DIP switch A1 to I and set parameter E3-00 to 0 (0 to 20 mA) or 1 (4 to 20 mA).
- To select voltage as the input type, set DIP switch A1 to V and set parameter E3-00 to 2 (0 to 10V) or 3 (0 to 5 V).

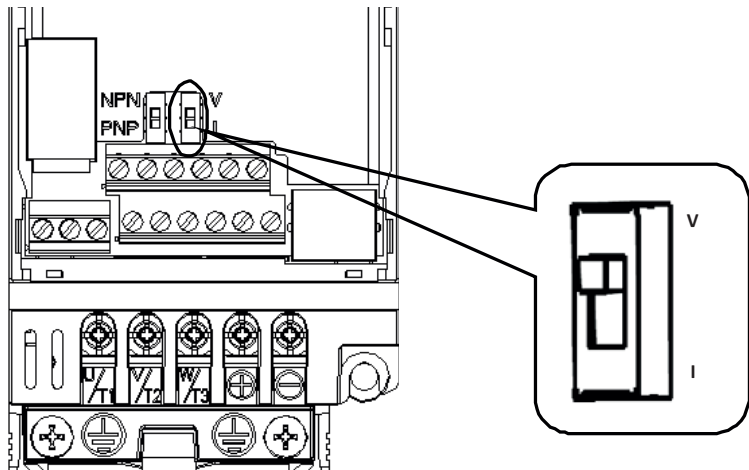

Figure 4.4.2 DIP Switch A1

Table 4.4.1 DIP Switch A1 Settings (Terminal A1)

Setting	Description
V	Voltage input (0 to 10 V (default) or 0 to 5 V)
I	Current input (4 to 20 mA or 0 to 20 mA)

4.6 Wiring Checklist

Table 4.6 Wiring Checklist

<input type="checkbox"/>	No.	Item	Page
Power Supply Voltage and Output Voltage			
<input type="checkbox"/>	1	Power supply voltage is within the voltage range of specified drive input.	
<input type="checkbox"/>	2	The motor voltage matches the drive output specifications.	
<input type="checkbox"/>	3	The drive rating matches the motor rating.	
Main Circuit Wiring			
<input type="checkbox"/>	4	An MCCB of proper specifications is connected between the drive and motor.	
<input type="checkbox"/>	5	Power cables are correctly connected to drive input terminals R/L1, S/L2 and T/L3.	
<input type="checkbox"/>	6	Motor terminals and drive terminals U/T1, V/T2 and W/T3 are in same phase sequence. (Otherwise the motor will rotate reversely)	
<input type="checkbox"/>	7	Power supply and motor power cable complies with electrician regulations.	
<input type="checkbox"/>	8	The drive is properly grounded.	
<input type="checkbox"/>	9	Drive terminal screws of the main circuit and ground are tightened.	
<input type="checkbox"/>	10	<p>An MC is installed for each motor if a single drive runs more than on motor.</p> <p style="text-align: center;">MC1~MCn Magnetic Contactor</p> <p>Note: Set MC1 to MCn OFF before operating the drive. Do not switch MC1 to MCn ON or OFF during run.</p>	
<input type="checkbox"/>	11	When using a braking resistor or braking unit, an MC is installed on the drive input side and able to shut off the power to drive when overloaded.	
Control Circuit Wiring			
<input type="checkbox"/>	12	Twisted-pair cables are used for all drive control circuit wiring.	
<input type="checkbox"/>	13	Shielded cables are connected to the terminals.	
<input type="checkbox"/>	14	Options (if any) are properly installed.	
<input type="checkbox"/>	15	No wiring mistakes.	
<input type="checkbox"/>	16	Do not use a buzzer to check wiring.	
<input type="checkbox"/>	17	The control circuit terminal screws are tightened.	
<input type="checkbox"/>	18	No cable clippings or screws are left inside the drive enclosure.	
<input type="checkbox"/>	19	Control circuit wiring and main circuit wiring are separated.	

Chapter 5 | Keypad and Parameters

5.1 Keypad

Use the keypad to enter RUN and STOP commands, display data, fault, alarm and set parameters.

5.1.1 Keys and Displays

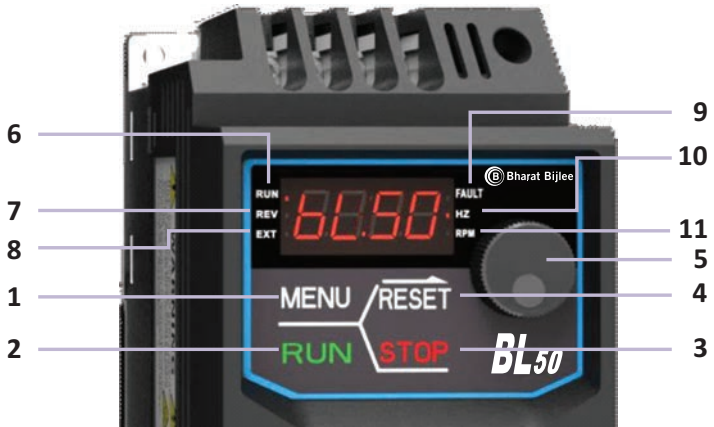

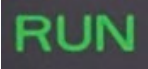











Figure 5.3.1 Keypad





























Table 5.1.1.2 Keypad Keys and Displays

No.	Display	Name	Function
1		MENU Key	<ul style="list-style-type: none"> ● Enters or exits the parameter group ● Switches the displayed menu
2		RUN Key	Forward/reverse selection
3		STOP Key	Stops the drive. Refer to Table 5.1.2.2
4		RESET Key	<ul style="list-style-type: none"> ● Moves the cursor to the right Resets the drive to clear a fault situation
5		Non-Slip Setting Dial	<p>Press it as “ENTER” key:</p> <ul style="list-style-type: none"> ● Enters parameter value, parameter and setting ● Enters parameter setting menu. ● Confirms the frequency set by the dial <p>Press it as “Dial” key :</p> <p>Increases or decreases parameter numbers, setting value and frequency</p>
6		RUN Light	Refer to Table 5.1.2.2
7		REV Light	Refer to Table 5.1.2.2
8		EXT Light	Refer to Table 5.1.2.2
9		Fault Light	Refer to Table 5.1.2.2
10		Hz Light	Refer to Table 5.1.2.2
11		RPM Light	Refer to Table 5.1.2.2

5.1.2 Keypad Display







5.1.2.1 LED Display

Table 5.1.2.1 LED Display

Number /Letter	LED Display	Number /Letter	LED Display	Number /Letter	LED Display	Number /Letter	LED Display
0		9		i		r	
1		A		J		S	
2		b		K	Nil	t	
3		c		L		U	
4		d		M	Nil	v	
5		E		n		W	Nil
6		F		o		X	Nil
7		G		P		y	Nil
8		H		q	Nil	Z	Nil

5.1.2.2 LED Indication

Table 5.1.2.2 LED Indication

Indicator Light	Lit	Blinking	Off
	Drive in operation	<ul style="list-style-type: none"> • Drive in deceleration • Out frequency below the minimum frequency 	Drive not in operation
	Rotating reversely	Nil	Nil
	Allows Run commands only from a remote source	Nil	Nil
	During fault	Nil	Normal operation
	Displaying output frequency	Nil	Nil
	Displaying output speed	Nil	Nil

5.1.3 Keypad Programming

- Keypad Display Menu Structure
 - A. Standard setting mode: Press MENU to switch among monitor group, A1-00 parameter group and A2-00 user-defined parameter group. Press ENTER, MENU, Non-slip setting dial, and RESET to monitor and edit settings.
 - B. Holding MENU for 3 seconds for entering User Parameter A2-00
 - C. During-operation setting mode: During operation in Local mode, use the non-slip setting dial to change the drive output frequency.
 - D. Holding Non-slip setting dial for 3 seconds in menu level can enter forward and reverse switching page, for more detail please refer to parameter b1-13.

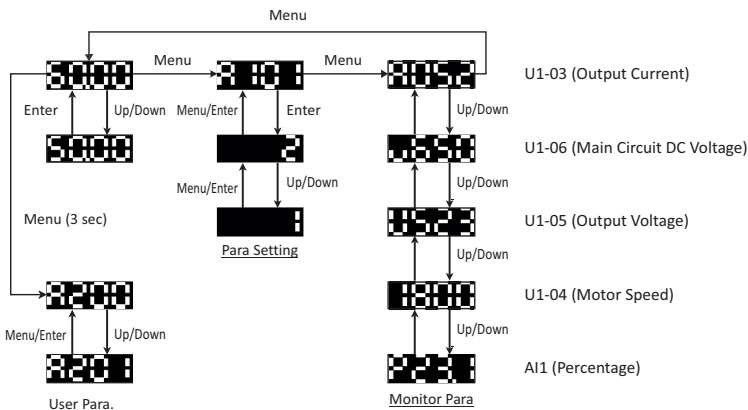

5.2 Parameter List

Parameter	Name	Description	Setting Range
Group A, Initialization			
A1: Basic Settings			
A1-01 <4>	Access Level Selection	Selects access level (edit/view) 0: View Only Access to only parameter A1-01. 1: User-Defined Parameter Access Access to only parameter A1-01 and A2-00 to A2-15. 2: All Parameter Access All parameters can be edited and viewed	Default : 2 Min.: 0 Max.: 2
A1-02	Control Method Selection	0: Open-Loop V/F Control 1: Sensorless Voltage Vector Control (SVVC) (Open-Loop)	Default: 0 Range: 0, 1
A1-03	Reset	0: No initialization 2520: Resets 2-Wire Sequence / 50Hz / 200V 2522: Resets 2-Wire Sequence / 50Hz / 220V 2523: Resets 2-Wire Sequence / 50Hz / 230V 2620: Resets 2-Wire Sequence / 60Hz / 200V 2622: Resets 2-Wire Sequence / 60Hz / 220V 2623: Resets 2-Wire Sequence / 60Hz / 230V 3520: Resets 3-Wire Sequence / 50Hz / 200V 3522: Resets 3-Wire Sequence / 50Hz / 220V 3523: Resets 3-Wire Sequence / 50Hz / 230V 3620: Resets 3-Wire Sequence / 60Hz / 200V 3622: Resets 3-Wire Sequence / 60Hz / 220V 3623: Resets 3-Wire Sequence / 60Hz / 230V 2538: Resets 2-Wire Sequence / 50Hz / 380V 2541: Resets 2-Wire Sequence / 50Hz / 415V 2544: Resets 2-Wire Sequence / 50Hz / 440V 2546: Resets 2-Wire Sequence / 50Hz / 460V 2638: Resets 2-Wire Sequence / 60Hz / 380V 2641: Resets 2-Wire Sequence / 60Hz / 415V 2644: Resets 2-Wire Sequence / 60Hz / 440V 2646: Resets 2-Wire Sequence / 60Hz / 460V 3538: Resets 3-Wire Sequence / 50Hz / 380V 3541: Resets 3-Wire Sequence / 50Hz / 415V 3544: Resets 3-Wire Sequence / 50Hz / 440V	Default: 0 Range: 0~9999

Parameter	Name	Description	Setting Range																								
		3546: Resets 3-Wire Sequence / 50Hz / 460V 3638: Resets 3-Wire Sequence / 60Hz / 380V 3641: Resets 3-Wire Sequence / 60Hz / 415V 3644: Resets 3-Wire Sequence / 60Hz / 440V 3646: Resets 3-Wire Sequence / 60Hz / 460V																									
A1-04	Password	Set password to parameter A1-05 and enter the password to parameter A1-04 to unlock it.	Default : 0000 Min.: 0000 Max.: 9999																								
A1-05	Password Setting	Parameters A1-01 to A1-03, A1-06, A2-01 to A2-15 cannot be edited until correct password is entered to A1-04																									
A1-07	Pump mode enable selection	Set whether the pump mode is ON 0: Standard mode 1: Pump mode (single pump) Only FW version 1.53 or later is supported	Default: 0 Min.: 0 Max.: 1 Unit: -																								
A2 : User-Defined Parameters																											
A2-00 to A2- 15	User-Defined Parameters 1 to 16	<p>Selects up to 16 parameters and assigns them to parameter A2-00 to A2-15. Saved parameters can be viewed in User-Defined Parameter Access. To assign specific parameters to A2-00 to A2-15, set parameter A1-01 to 2. The saved parameters A2-00 to A2-15 can only be viewed if A1-01 is set to 1</p> <p>Can be modified during running period</p> <table border="1"> <thead> <tr> <th>Parameter</th> <th>Default</th> <th>Name</th> </tr> </thead> <tbody> <tr> <td>A2-00</td> <td>b1-00</td> <td>Frequency command selection</td> </tr> <tr> <td>A2-01</td> <td>b1-01</td> <td>Operation command selection</td> </tr> <tr> <td>A2-02</td> <td>C1-00</td> <td>Acceleration time 1</td> </tr> <tr> <td>A2-03</td> <td>C1-01</td> <td>Deceleration time 1</td> </tr> <tr> <td>A2-04</td> <td>C3-00</td> <td>Torque compensation gain</td> </tr> <tr> <td>A2-05</td> <td>d1-02</td> <td>Maximum output frequency</td> </tr> <tr> <td>A2-06</td> <td>d1-03</td> <td>Maximum output voltage</td> </tr> </tbody> </table>	Parameter	Default	Name	A2-00	b1-00	Frequency command selection	A2-01	b1-01	Operation command selection	A2-02	C1-00	Acceleration time 1	A2-03	C1-01	Deceleration time 1	A2-04	C3-00	Torque compensation gain	A2-05	d1-02	Maximum output frequency	A2-06	d1-03	Maximum output voltage	Range: A1-00 to F1- 25
Parameter	Default	Name																									
A2-00	b1-00	Frequency command selection																									
A2-01	b1-01	Operation command selection																									
A2-02	C1-00	Acceleration time 1																									
A2-03	C1-01	Deceleration time 1																									
A2-04	C3-00	Torque compensation gain																									
A2-05	d1-02	Maximum output frequency																									
A2-06	d1-03	Maximum output voltage																									

Parameter	Name	Description			Setting Range
		Parameter	Default	Name	
		A2-07	d1-04	Basic motor frequency	
		A2-08	d1-05	Basic motor voltage	
		A2-09	o2-06	Motor running direction	
		A2-10	b1-10	Power ON/OFF selection	
		A2-11	E2-00	Relay1 function selection	
		A2-12	E3-00	Analog A1 input level	
		A2-13	E3-01	Analog A1 function	
		A2-15	-		
		A2-13	-		
A2-32	User-Defined Parameter Automatic Save	Saves the most recently edited parameters. 0: Do not save list of recently edited parameters 1: Save list of recently edited parameters			Default: 0 Range: 0, 1
Group b, Application					
b1: Operation Mode Selection					
b1-00	Frequency Command Selection 1	0: Keypad 1: Control Circuit Terminal (Analog Input) 2: Terminal Up/Down 3: Modbus Communication			Default : 0 Min.: 0 Max.: 3
b1-01	Run Command Selection 1	0: Keypad 1: Control Circuit Terminal (Sequence Control Input) 2: Modbus Communication			Default : 0 Min.: 0 Max.: 2
b1-02	Stopping Method Selection	0: Ramp to Stop 1: Coast to Stop 2: DC Braking to Stop 3: Coast to Stop with Timer			Default : 0 Min.: 0 Max.: 3

Parameter	Name	Description	Setting Range
b1-03	Reverse Rotation Selection	<p>0 : Reverse Rotation Enabled Drive accepts a run command of both forward and reverse directions</p> <p>1 : Reverse Rotation disabled Drive can accept only run command of forward direction</p>	Default : 0 Min.: 0 Max.: 3
b1-05	Run Command Action after Switch	<p>0 : Ignore Active Run Command at the New Source If a Run command at the new source is active, the drive will not start or the drive will stop operation if it was running when switching from the old source to the new source. The drive can start only when the Run command is removed and given again.</p> <p>1 : Accept Active Run Command at the New Source If a run command at the new source is active, the drive will accept it and run the motor immediately right after switching from the old source to the new source.</p>	Default : 0 Min.: 0 Max.: 3
b1-06	Run Command Selection during Programming	<p>0 : Run command disabled during Programming</p> <p>1 : Run command enabled during Programming</p> <p>2 : Prohibit programming during run The programming mode cannot be displayed during run except for monitoring parameter Group U.</p>	Default : 0 Min.: 0 Max.: 2
b1-07 <7>	Frequency Command Selection 2	<p>0 : Keypad</p> <p>1 : Control Circuit Terminal (Analog Input)</p> <p>2 : Terminal Up/Down</p> <p>3 : Modbus Communication</p>	Default : 0 Min.: 0 Max.: 3
b1-09 <7>	Frequency superposition Selection	<p>0 : Disabled</p> <p>1 : Enabled</p>	Default : 0 Range: 0, 1

Parameter	Name	Description	Setting Range
b1-10	Run Command at Power up	Determines to accept or ignore an active Run command from Remote during power up. 0 : Ignore Drive ignores an active run command during power up 1 : Accept Drive accepts an active run command at power up and runs the motor immediately.	Default : 0 Min.: 0 Max.: 1
b1-11	Retained		
b1-12	Local/ Remote switching Enable during Operating	0 : Disabled 1 : Enabled	Default : 0 Range: 0, 1
b1-13	Forward and Reverse Selection from Keypad	0 : Disabled 1 : Enabled	Default : 0 Range: 0, 1
b2 : DC Braking			
b2-00	Zero Speed Holding (DC Braking) Start Level	Sets the start frequency for Zero Speed Holding (DC braking). Enabled when b1-02 (Stopping Method Selection) is set to 0 (Ramp to Stop)	Default : 0.5Hz Min.: 0.0Hz Max.: d1-02
b2-01	DC Braking Current	Sets the DC braking current as a percentage of the drive rated current	Default : 0% Min.: 0% Max.: 100%
b2-02	DC Braking Time at Start	Sets the DC braking time at start to stop a coasting motor before restarting it or to apply braking torque at start when high starting torque is needed. Disabled when set to 0.00.	Default : 0.00 s Min.: 0.00 s Max.: 99.99 s
b2-03	DC Braking Time at Stop	Sets the DC braking time at stop to stop a motor rotating with high inertia. Disabled when set to 0.00.	Default : 0.00s Min.: 0.00 s Max.: 99.99 s

Parameter	Name	Description	Setting Range
b3 : Speed Search			
b3-00	Speed Search Setting	0 : Disabled 1 : Enabled and searched from the highest frequency 2 : Enabled and searched from the frequency Command	Default : 0 Min.: 0 Max.: 2
b3-01	Speed Search Operating Current	Sets the current level as a percentage of the drive rated current below which Speed Search is deactivated.	Default : 120% Min.: 30% Max.: 140%
b3-02 <7>	Voltage Recovery Time	Sets the search speed in the output voltage restoring to the time set V / f voltage curve required	Default : 0.6s Min.: 0.3s Max.: 5.0s
b3-04 <7>	Speed search deceleration time	Sets the search speed in the deceleration time (The maximum output frequency to the minimum output frequency deceleration time)	Default : 2.0s Min.: 0.1s Max.: 10.0s
b3-05 <7>	Search speed in V / f	In order to reduce the speed of search output current by the V / f curve calculated by multiplying the voltage set value b3-05 by adjusting the setting, the speed can be suppressed search output current.	Default: 100% Min.: 10% Max.: 100%
b4 : Timer Function			
b4- 00 <7>	Timer Function On-Delay Time	Sets the on-delay and off-delay time to switch on/off the timer output.	Default : 0.1 s Min.: 0.1 s Max.: 3000.0 s
b4- 01 <7>	Timer Function Off-Delay Time		Default : 0.1 s Min.: 0.1 s Max.: 3000.0 s
b5 : PID Control			
b5-00	PID Control Setting	0 : PID Control Disabled 1 : PID Control Enabled (D Control for Deviation Signal U4-01) 2 : PID Control Enabled (D Control for Feedback Signal U4-05)	Default: 0 Min.: 0 Max.: 5

Parameter	Name	Description	Setting Range
		3 : PID Control Enabled (Frequency Command + PID Output from D Controlled Deviation) 4 : PID Control Enabled (Frequency Command + PID Output from D Controlled Feedback) 5 : PID Control Disabled, but b5-14/b5-15 (PID Sleep) and b5-29/b5-30(PID Wake-up) Enabled	
b5-01	Proportional Gain Setting (P)	Sets the P gain for PID input.	Default: 1.00 Min.: 0.00 Max.: 25.00
b5-02 <4>	Integral Time Setting (I)	Deviation appears between PID target value and feedback value when using only proportional control. To reduce the deviation, set integral time (I).	Default: 1.0s Min.: 0.0s Max.: 360.0s
b5-03 <4>	Integral Time (I) Limit Setting	Sets the maximum output from the I (integral) control as a percentage of the maximum frequency (d1-02)	Default: 100.0% Min.: 0.0% Max.: 100.0%
b5-04 <4>	Derivative Time (D)	Sets derivative time for D control.	Default: 0.00 s Min.: 0.00 s Max.: 10.00 s
b5-05 <4>	PID Output Limit	Sets the maximum output from PID control as a percentage of the maximum frequency.	Default: 100.0% Min.: 0.0% Max.: 100.0%
b5-06 <4>	PID Bias Voltage Adjustment	Sets the PID bias voltage adjustment as a percentage of the maximum frequency to add to the PID control output.	Default: 0.0% Min.: -100% Max.: 100.0%
b5-07 <4>	PID Primary Delay Time	Sets the delay time for the PID output filter.	Default: 0.00 s Min.: 0.00 s Max.: 10.00 s
b5-08	PID Output Selection	0 : Normal PID Output 1 : Reverse PID Output Reverses the +/- sign of the PID	Default: 0 Min.: 0 Max.: 1
b5-09	PID Output Gain	Sets a PID output gain	Default: 1.00 Min.: 0.00 Max.: 25.00

Parameter	Name	Description	Setting Range
b5-10	PID Output Reverse Selection	Determines whether or not a negative PID output reverses the drive rotating direction. 0 : Reverse Disabled 1 : Reverse Enabled	Default: 0 Min.: 0 Max.: 1
b5-11	PID Feedback Low /High Detection Selection	0 : Multi-Function Output Only 1 : Feedback Low /High Alarm The drive continues operation when an alarm is displayed) 2 : Feedback Low /High Fault A fault will cause the drive to stop the motor. 3 : Multi-Function Output only when PID is Disabled Same action as b5-11=0. 4 : Feedback Low /High Alarm (detection disabled when PID is disabled) 5 : Feedback Low /High Fault (detection disabled when PID is disabled) 6 : Multi-Function Output (Keep running without an alarm displayed) 7 : Multi-Function Output Only (detection working when drive running or not)	Min.: 0 Max.: 7
b5-12	PID Feedback Low Detection Level	Sets the PID feedback level used for detection. When the PID feedback falls below this level for longer than the time set to b5- 13, PID feedback loss will be detected.	Default: 0% Min.: 0% Max.: 100%
b5-13	PID Feedback Low Detection Time	Sets the PID feedback time used for detection. When the PID feedback falls below the level set to b5-12 for longer than this time, PID feedback loss will be detected.	Default: 1.0 s Min.: 0.0 s Max.: 25.5 s
b5-14	PID Sleep Start Level	Sets the PID level to trigger the drive to sleep.	Default: 0.0Hz Min.: 0.0Hz Max.: <5>
b5-15	PID Sleep Delay Time	Sets the delay time used to activate / deactivate the PID Sleep function.	Default: 0.0 s Min.: 0.0 s Max.: 25.5 s

Parameter	Name	Description	Setting Range
b5-16	PID Command Acc./Dec. Time	Sets the PID command acceleration / deceleration time used for PID target.	Default: 0.0 s Min.: 0.0 s Max.: 20.0 s
b5-17	PID Target Selection	0 : PID Target Disabled 1 : PID Target Enabled	Default: 0 Range: 0, 1
b5-18	PID Target Value	Sets the PID target value as a percentage of the maximum output frequency when b5-17 is set to 1. Disabled when b5-17=0	Default: 0.00% Min.: 0.00% Max.: 99.99%
b5-19	PID Target Value Units	0 : 0.01Hz 1 : 0.01% (Maximum Frequency is 100%) 2 : r/min. (Number of Motor Poles must be set) 3 : User Defined (Defined by b5-24 and b5-25)	Default: 1 Min.: 0 Max.: 3
b5-20 <7>	PID Output Min.	Sets the lower limit as a percentage of the maximum output frequency set in d1-02 for PID output.	Default: 0.0% Min.: -100% Max.: 100.0%
b5-21 <7>	PID Input Limit	The higher PID Input value is, the higher PID output value will be. Sets this parameter to limit the PID input value.	Default: 1000% Min.: 0.0% Max.: 1000%
b5-22 <7>	PID Feedback High Detection Level	Sets the PID feedback to exceed the detected value with the highest output frequency of 100%.	Default: 100% Min.: 0% Max.: 100%
b5-23	PID Feedback High Detection Time	Sets the time for PID feedback high detection. PID feedback high will be detected when the feedback exceeds the level set in b5-22 for longer than the time set in b5-23.	Default: 1.0 s Min.: 0.0 s Max.: 25.5 s
b5-24	PID Target Display Value	Sets a value to display to U4-00 and U4-03 when the drive runs at the maximum output frequency	Determined by b5-19 Min.: 1 Max.: 9999
b5-25	PID Target Display Digits	Sets the number of decimal places to display. 0 : No Decimal Places 1 : 1 Decimal Place 2 : 2 Decimal Places 3 : 3 Decimal Places	Determined by b5-19 Min.: 0 Max.: 3

Parameter	Name	Description	Setting Range
b5-26 <7>	Frequency Command Display During PID	0 : Displays frequency command after the PID compensation 1 : Displays frequency command before the PID compensation.	Default: 0 Min.: 0 Max.: 1
b5-27 <7>	PID Output Direction	Sets the direction when PID output value is minus. 0 : Reverse is not allowed 1 : Reverse is allowed	Default: 1 Min.: 0 Max.: 1
b5-28	PID Disconnection Output Frequency	When a PID feedback disconnection alarm occurs, the drive will run at the frequency set to b5-28, and return to PID control when disconnection alarm is reset.	Default: 30.0 Hz Min.: 0.0Hz Max.: <5>
b5-29 <7>	PID Wake-up Level	Sets the PID Wake-up level	Default : 0.0 Hz Min.: 0.0 Hz Max.: <5>
b5-30 <7>	PID Wake-up delay time	Sets the PID Wake-up delay time	Default: 0.0 s Min.: 0.0 s Max.: 25.5 s
b9 : Zero speed DC brake function			
b9-02	Zero speed DC braking enabled	0 : off 1 : open	Default: 0 Min.: 0 Max.: 1 Unit: -
b9-03	Zero speed DC braking time	Set the zero speed DC function actuation time	Default: 0.1 s Min.: 0 s Max.: 99.99 s Unit: 0.01 s
Group C, Tuning			
C1 : Acc./Dec. Time			
C1-00 <4>	Acceleration Time 1	Sets the time that the drive accelerates from 0Hz to the maximum output.	Default: 10.0 s Min.: 0.0 s Max.: 3600 s
C1-01 <4>	Deceleration Time 1	Sets the time that the drive decelerates from the maximum output to 0Hz.	
C1-02 <4>	Acceleration Time 2	Sets the time that the drive accelerates from 0Hz to the maximum output.	
C1-03 <4>	Deceleration Time 2	Sets the time that the drive decelerates from the maximum output to 0Hz.	
C1-08	Fast Stop Time	Sets the time to stop the drive faster.	

Parameter	Name	Description	Setting Range
C1-11	Jog Acc. Time	Sets the time to accelerate from 0 Hz to Jog Frequency Command (L1-16).	Default: 10.0 s Min.: 0.0 s Max.: 3600 s
C1-12	Jog Dec. Time	Sets the time to decelerate from Jog Frequency Command (L1-16) to 0 Hz.	Default: 10.0 s Min.: 0.0 s Max.: 3600 s
C2 : S-Curve Characteristics			
C2-00	S-Curve Characteristic at Acc. Start	Sets S-curve times for each acceleration or deceleration. Actual Acceleration Time = Determined Acc. Time +(C2-00+C2-01)/ 2 Actual Deceleration Time = Determined Dec. Time+(C2-02+C2-03) / 2	Default: 0.00 s Min.: 0.00 s Max.: 10.00 s
C2-01	S-Curve Characteristic at Acc. End		Default: 0.00 s Min.: 0.00 s Max.: 10.00 s
C2-02	S-Curve Characteristic at Dec. Start		Default: 0.00 s Min.: 0.00 s Max.: 10.00 s
C2-03	S-Curve Characteristic at Dec. End		Default: 0.00 s Min.: 0.00 s Max.: 10.00 s
C3 : Torque Compensation			
C3-00	Torque Compensation Gain	Sets the gain for the motor 1 Torque compensation	Default: 0.50 Min.: 0.00 Max.: 2.50
C3-02	Torque Compensation Primary Delay Time	Sets the Torque compensation primary delay time.	Default: 0.010 s Min.: 0.000 s Max.: 9.999 s
C5 : Slip Compensation			
C5-00	Slip Compensation Gain	Sets the slip compensation gain to improve the speed accuracy for heavy loads.	Default: 0.0 Min.: 0.0 Max.: 2.5
C5-01	Slip Compensation Primary Delay Time	Sets the slip compensation primary delay time to stabilize the motor speed or to improve the speed response.	Default: 100 ms Min.: 0 ms Max.: 9999ms

Parameter	Name	Description	Setting Range
C6 : Carrier Frequency			
C6-00	Carrier Frequency Selection	<p>Sets the switching frequency of the drive output transistors. Adjust this setting to reduce audible noise and leakage current.</p> <p>2: 2.0 kHz 3: 3.0 kHz 4: 4.0 kHz 5: 5.0 kHz 6: 6.0 kHz 7: 7.0 kHz 8: 8.0 kHz 9: 9.0 kHz 10: 10.0 kHz 11: 11.0 kHz 12: 12.0 kHz</p>	<p>Default: 8 Range: 2-12 Min.: 2</p>
C7 : SVVC (Sensorless Voltage Vector Control)			
C7-00	SVVC Proportional Gain	<p>According to application feature to set this gain, if the load is heavy increase the value, and vice versa to reduce this value. Recommend to adjust 10% roughly and then adjust 1% minute.</p>	<p>Default: 40 % Min.: 0 % Max.: 250 % <7></p>
C7-01	SVVC mode slip adjustment	<p>If the slip compensation is not obvious or there is too much current at low speed, the parameter can be adjusted to improve (low speed SVVC compensation constant correction)</p>	<p>Default: 100 Min.: 0 Max.: 250 Unit: 1</p>
Group L, Frequency Command			
L1 : Frequency Command			
L1-00 <4>	Frequency Command 1	<p>To use speed commands for each multi-step speed, set E1-□□ to 5,6,7 & 8 (multi-step speed command 1, 2, 3, 4). Sets E1-□□</p>	<p>Default: 5.00Hz Min.: 0.00Hz Max.: <5></p>
L1-01 <4>	Frequency Command 2	<p>to 9 for log frequency command The upper limit is determined by d1-02 and L2-00.</p>	<p>Default: 8.00 Hz Min.: 0.00 Hz Max.: <5></p>
L1-02 <4>	Frequency Command 3	<p>When L2-00 (Frequency Upper Limit) is adjusted, the exceeded frequency in L1-00 to L1-15 will be automatically set to the upper limit determined in L2-00.</p>	<p>Default: 10.00Hz Min.: 0.00 Hz Max.: <5></p>

Parameter	Name	Description	Setting Range
L1-03 <4>	Frequency Command 4	To use speed commands for each multi-step speed, set E1-□□ to 5,6,7 & 8 (multi-step speed command 1, 2, 3, 4). Sets E1-□□ to 9 for log frequency command The upper limit is determined by d1-02 and L2-00. When L2-00 (Frequency Upper Limit) is adjusted, the exceeded frequency in L1-00 to L1-15 will be automatically set to the upper limit determined in L2-00.	Default: 12.00Hz Min.: 0.00Hz Max.: <5>
L1-04 <4>	Frequency Command 5		Default: 15.00Hz Min.: 0.00Hz Max.: <5>
L1-05 <4>	Frequency Command 6		Default: 20.00Hz Min.: 0.00Hz Max.: <5>
L1-06 <4>	Frequency Command 7		Default: 25.00Hz Min.: 0.00Hz Max.: <5>
L1-07 <4>	Frequency Command 8		Default: 30.00Hz Min.: 0.00Hz Max.: <5>
L1-08 <4>	Frequency Command 9		Default: 35.00Hz Min.: 0.00Hz Max.: <5>
L1-09 <4>	Frequency Command 10		Default: 40.00Hz Min.: 0.00Hz Max.: <5>
L1-10 <4>	Frequency Command 11		Default: 42.00Hz Min.: 0.00Hz Max.: <5>
L1-11 <4>	Frequency Command 12		Default: 45.00Hz Min.: 0.00Hz Max.: <5>
L1-12 <4>	Frequency Command 13		Default: 50.00Hz Min.: 0.00Hz Max.: <5>
L1-13 <4>	Frequency Command 14		Default: 50.00Hz Min.: 0.00Hz Max.: <5>
L1-14 <4>	Frequency Command 15		Default: 50.00Hz Min.: 0.00Hz Max.: <5>
L1-15 <4>	Frequency Command 16		Default: 50.00Hz Min.: 0.00Hz Max.: <5>

Parameter	Name	Description	Setting Range
L1-16 <4>	Jog Frequency Command	Sets the Jog frequency command.	Default: 6.00 Hz Min.: 0.00Hz Max.: <5>
L2 : Frequency Upper/ Lower Limit			
L2-00	Frequency Command Upper Limit	Sets the upper limit as a percentage of the maximum output frequency	Default: determined by d1-02 Min.: 0.0 Hz Max.: determined by d1-02
L2-01	Frequency Command Lower Limit	Sets the lower limit as a percentage of the maximum output frequency	Default: 0.0 Hz Min.: 0.0 Hz Max.: determined by d1-02
L3 : Jump Frequency			
L3-00	Jump Frequency 1	Sets the Jump frequency range to avoid operation at the speed causing resonance in the machinery. Set L3-00, L3-01 and L3-03 to 0.0 Hz to disable Jump frequency.	Default: 0.0 Hz Min.: 0.0 Hz Max.: <5>
L3-01	Jump Frequency 2	When setting more than 1 Jump frequency, follow the condition below. $L3-00 \leq L3-01$	
L3-03	Jump Frequency 1	Sets the Jump frequency range to avoid.	Default: 1.0 Hz Min.: 0.0 Hz Max.: 20.0 Hz
L4 : Frequency Command Hold and Up/Down 2 Command			
L4-00	Frequency Command Hold	Determines whether or not to save the frequency command or the frequency bias (Up/Down 2) value when the Stop command is entered or the power supply is shut off. 0 : Clear the Up/Down frequency at stop 1 : Save the Up/Down frequency at stop 2 : Accept the Up/Down frequency at stop	Default: 0 Range: 0, 1, 2

Parameter	Name	Description	Setting Range
L4-01 <4>	Frequency Command Bias (Up/Down 2)	Sets the bias used to add to or subtract from the frequency command by Up/Down 2.	Default:0.00 Hz Min.: 0.00 Hz Max.: 99.99 Hz
L4-02 <4>	F r e q u e n c y C o m m a n d Acc./Dec Setting (UP2 / DOWN 2)	Sets the acceleration/deceleration times to increase or decrease the frequency command bias for Up/Down 2. 0 : Current Acc./Dec. Time 1 : Non-Current Acc./Dec. Time	Default: 0 Range: 0, 1
L4-03 <4>	Up/Down Frequency Command Save	Saves the frequency command from Up/Down 1 or Up/Down 2	Default: 0.00Hz Min.: 0.00 Hz Max.: <5>
L4-04	Frequency Command Save	0: Disabled 1: Enabled	Default: 0 Range 0, 1
L6 : Offset Frequency			
L6-00 <4><7>	Offset Frequency 1	As the correction value of the speed, the three kinds of bias frequencies can be added and subtracted to the frequency command. Select the offset frequency in E1-□□= 53, 54 and 55 (Offset Frequency 1 to 3).	Default: 0.0% Min.: -100% Max.: 100.0%
L6-01 <4><7>	Offset Frequency 2		
L6-02 <4><7>	Offset Frequency 3		
Group d, Motor Parameters			
d1: V/F Characteristics			
d1-00	Input Voltage Setting	Sets the input voltage of the drive. Always set the input voltage of the drive (not motor) to this parameter d1-00 (input voltage) 200 V Class : 200 V 400 V Class : 400 V	Default : A1-03 Min.: 155 V Max.: 255V <3>

Parameter	Name	Description	Setting Range
d1-01	V/F Pattern Selection	0 : 50 Hz (Constant Torque Characteristic 1) 1 : 60 Hz (Constant Torque Characteristic 2) 2 : 60 Hz (Constant Torque Characteristic 3), 50 Hz base 3 : 72 Hz (Constant Torque Characteristic 4), 60 Hz base 4 : 50 Hz (Derated Torque Characteristic 1) 5 : 50 Hz (Derated Torque Characteristic 2) 6 : 60 Hz (Derated Torque Characteristic 3) 7 : 60 Hz (Derated Torque Characteristic 4) 8 : 50 Hz (High Starting Torque Characteristic 1) 9 : 50 Hz (High Starting Torque Characteristic 2) A : 60 Hz(High Starting Torque Characteristic 3) B : 60 Hz(High Starting Torque Characteristic 4) C : 90 Hz, 60 Hz base D : 120 Hz, 60 Hz base E : 180 Hz, 60 Hz base F : 60Hz (Constant Torque Characteristic) (Default)	Default: F Range: 0 to 9; A to F
d1-02	Maximum Output Frequency	When d1-01 ≤ E, parameters d1-02 to d1-11 can be used to monitor the V/F pattern. When d1-01 = F, parameters d1-02 to d1-11 can be used to create a V/F pattern.	Default: <1> Min.: 25.0 Hz Max.: 400.0 Hz
d1-03	Maximum Voltage		Default: <1> Min.: 0.0 V Max.: 255.0 V <3>
d1-04	Base Frequency		Default: <1> Min.: 0.0 Hz Max.: Defined by d1-02
d1-05	Base Voltage		Default: <1> Min.: 0.0 V Max.: 255.0 V <3>
d1-06	Middle Output Frequency		Default: <1> Min.: 0.0 Hz Max.: Defined by d1-02
d1-07	Middle Output Frequency Voltage		Default: <1> Min.: 0.0 V Max.: 255.0 V <3>

Parameter	Name	Description	Setting Range
d1-08	Minimum Output Frequency	When d1-01 ≤ E, parameters d1-02 to d1-11 can be used to monitor the V/F pattern.	Default: <1> Min.: 0.0 Hz Max.: Defined by d1-02
d1-09	Minimum Output Frequency Voltage	When d1-01 = F, parameters d1-02 to d1-11 can be used to create a V/F pattern.	Default: <1> Min.: 0.0 V Max.: 255.0 V <3>
d1-15	Motor 2 Base Frequency	Set the motor 2 V/F pattern	Default: <1> Min.: 0.0 Hz Max.: Defined by d1-02
d1-20	Motor 2 Minimum Output Frequency Voltage		Default: <1> Min.: 0.0 V Max.: 255.0 <3>
d2 : Motor Parameters			
d2-00	Motor Rated Current	Sets the motor rated current. This will be set automatically during Auto-Tuning.	Default: o2-03 (A) Min.: 10% of drive rated current (A) Max.: 200% of drive rated current (A)
d2-01	Motor Rated Speed	Sets the motor rated speed. This will be set automatically during Auto-Tuning.	Default: o2-03 Min.: 0.00 Hz Max.: 20.00 Hz
d2-02	Motor No-Load Current	Sets the motor no-load current. This will be set automatically during Auto-Tuning.	Default: o2-03 Min.: 0 A Max.: d2-00
d2-03	Number of Motor Poles	Sets the number of motor poles. This will be set automatically during Auto-Tuning.	Default: 4 Min.: 2 Max.: 48
d2-04	Motor Line-to-Line Resistance	Sets the line-to-line resistance. This will be set automatically during Auto-Tuning.	Default: o2-03 Min.: 0.000 Ω Max.: 65.00 Ω

Parameter	Name	Description	Setting Range
d2-05	Motor Leakage Inductance	Sets the voltage drop caused by the motor leakage inductance relative to the motor rated frequency and current. This will be set automatically during Auto-Tuning.	Default: o2-03 Min.: 0.00 mH Max.: 650.0 mH
d2-06	Motor Rotor Resistance	Sets the motor rotor resistance. This will be set automatically during Auto-Tuning.	Default: o2-03 Min.: 0.000 Ω Max.: 65.00 Ω
d2-07	Motor Mutual Inductance	Sets the motor mutual inductance. This will be set automatically during Auto-Tuning.	Default: o2-03 Min.: 0.0 mH Max.: 6500 mH
d2-10	Motor Rated Capacity	Sets the motor rated capacity. This will be set automatically during Auto-Tuning. (1HP = 0.746 kW)	Default: o2-03 Min.: 0.00 kW Max.: 650.0kW
Group E, Multi-Function Terminals			
E1 : Multi-Function Digital Inputs			
E1-00	Terminal S1 Function Selection	0: 2-Wire Sequence Control (Forward/Stop) / 3-Wire Sequence Control (Stop)	Default : 0 Min.: 0 Max.: 0~73/100~173
E1-01	Terminal S2 Function Selection	1: 2-Wire Sequence Control (Reverse/Stop) / 3-Wire Sequence Control (Stop)	Default : 1 Min.: 0 Max.: 0~73/100~173
E1-02	Terminal S3 Function Selection	2 : 3-Wire Sequence 3 : Local/Remote Selection 5 to 8 : Multi-Step Speed Command 1 to 4 9 : Jog Frequency	Default : 23 Min.: 0 Max.: 0~73/100~173
E1-03	Terminal S4 Function Selection	10: Up Command 11: Down Command 12: Up 2 Command	Default : 39 Min.: 0 Max.: 0~73/100~173
E1-04	Terminal S5 Function Selection	13: Down 2 Command 14, 15 : FJOG/RJOG Command 16: Acc./Dec. Time Selection 1 18: Acc./Dec. Ramp Hold 19: Baseblock Command (Normal Open) 20: Retain 21: Fast Stop (Normal Open) 22: Fast Stop 23 to 38 : External Fault 39: Fault Reset	Default : 9 Min.: 0 Max.: 0~73/100~173

Parameter	Name	Description	Setting Range
E1-05	Terminal S6 Function Selection	40 : oH2 (AC drive Overheat Alarm) 45 : Communication Mode 46 : PID Disable 47 : PID Integral Reset 48: PID Integral Hold 49 : PID Soft-Start On/Off 50 : PID Input Characteristics Switch 52 : Timer Input 53, 54, 55 : Offset Frequency 1/ 2/ 3 58/59 : Retain 60 : Program Lockout 61 : Analog Frequency Command Hold 62 : Retain 65 : DC Braking 69 : Drive Enabled (Note) 0xx/1xx are anti-logic	Default : 19 Min.: 0 Max.: 0~73/100~173
E1-08	2/3-wire control switch	0:2/3 line control mode 1 1:2/3 line control mode 2	Default: 0 Min.: 0 Max.: 1
E1-09	DI terminal delay time	Used to set the delay time of the inverter for the change when the status of the DI terminal changes.	Default: 0 ms Min.: 0 Max.: 500 ms
E2 : Multi-Function Digital Output			
E2-00	Relay 1 Function Selection	0 : During Run 1 : Zero Speed Holding 2 : Frequency (Speed) Agree 3 : User-Defined Frequency (Speed) Agree 4 : Drive Ready 5 : Uv (Undervoltage) Detection 6 : During Baseblock 8 : Frequency Command Source 9 : Frequency Command Loss 10 : Run Command Source 11 : Fault 12 : Communication Mode 13 : Alarm 14 : Fault Restart 15 : Timer Output	Default : 11 Range : 0 to 49 / 100 to 149

Parameter	Name	Description	Setting Range
		16 : Frequency (FOUT) Detection 1 17 : Frequency (FOUT) Detection 2 18 : Overvoltage/ Undervoltage Detection 1 (normal open) 20 : Retain 22 : During Reverse 23 : Motor 1/2 Selection 24 : During Regeneration 25 : During Restart 26 : Motor Overload Pre-Alarm (oL1) 27 : Drive Overheat Pre-Alarm (oH) 28 : Retain 35 : During Frequency Output 36 : Drive Enabled 37 : Watt Hour Pulse Output 38 : Local/Remote Mode 39 : During Speed Search 40 : PID Feedback Low 41 : PID Feedback High 44 : During Fast Stop 47 & 48 : Retain 49 : Brake Control (Desired frequency attained) 52 : Timer Input 100 to 149 : 0 to 49 with Inverse Output	
E3 : Multi-Function Analog Input			
E3-00	Terminal A1 Signal Level Selection	0: 0 to 20 mA 1: 4 to 20 mV 2: 0 to 10 V 3: 0 to 5 V	Default: 0 Min.: 0 Max.: 3
E3-01	Terminal A1 Function Selection	0 : Main Frequency Command 2 : Output Frequency Lower Limit 3 : Auxiliary Frequency Command 4 : Output Voltage Bias 5 : Acc./Dec. Time Gain (Decrease Only) 6 : DC Braking (DB) Current 7 : Stall Prevention Level During Run 8 : PID Feedback 9 : PID Target 11 : Overtorque/ Undertorque Detection	Default : 0 Range : 0 to 21

Parameter	Name	Description	Setting Range
		18: Communication Mode 1 19 : Communication Mode 2 21 : Retain<7>	
E3-02 <4>	Terminal A1 Input Gain	Sets the terminal A1 input gain as a percentage when inputting 10V	Default : 100.0 % Min.: -999 % Max.: 999.9 %
E3-03 <4>	Terminal A1 Input Voltage Bias	Sets the terminal A1 input voltage bias as a percentage when inputting 0V	Default: 0.0 % Min.: -999 % Max.: 999.9 %
E3-04 <7>	Terminal A1 (4-20mA) lost choice	0 : no disconnection selection 1 : Operate according to P4-03 frequency setting and display ANL 2 : Speed to 0Hz and display ANL 3 : Stop immediately and display ACE	Default: 0 Range: 0 to 3
E3-05	Terminal A1 Input Filter Time	Sets the terminal A1 primary delay filter time, which can eliminate the interference	Default: 0.05 s <7> Min.: 0.00 s Max.: 2.00 s
E3-13	AI minimum input	AI minimum input. When the AI original signal is less than E3-13, it will be limited to E3-13.	Default: 0 Min.: 0 Max.: 9.9 Unit: -
E4 : Multi-Function Analog Output			
E4-01	Terminal FM Monitor Selection	Selects the terminal FM monitor. 0 : Frequency Command 1 : Output Frequency 2 : Output Current 3 : Motor Speed 4 : Output Voltage 5 : DC Voltage 6 : Output Power 8 : AI1 Input 10 : Soft Starter Output Frequency 12 : Retain <7>	Default: 1 Range: 0 to 12

Parameter	Name	Description	Setting Range
E4-02 <4>	Terminal FM Monitor Gain	Sets the terminal FM monitor gain.	Default: 100.0 % Min.: -999 % Max.: 999.9 %
E4-03 <4>	Terminal FM Monitor Voltage Bias	Sets the terminal FM voltage bias.	Default: 0.0 % Min.: -999 % Max.: 999.9 %
E6 : Optional Communication Card Settings			
E6-06	Drive Station Address	Sets the drive station address.	Default: 1 Range: 1 to 31
E6-07	RS-485 Communication Baud Rate Setting	Sets the baud rate for terminals SG(+) and SG(-) of RS-485 communication. 0: 1200 bps (bit/sec) 1: 2400 bps 2: 4800 bps 3: 9600 bps 4: 19200 bps 5: 38400 bps	Default: 3 Range: 0 to 5
E6-08	RS-485 Communication Parity Selection	Selects the communication parity for terminals SG(+) and SG(-) of RS-485 communication. 0: 8, N, 2 (Modbus RTU) 1: 8, N, 1 (Modbus RTU) 2: 8, E, 1 (Modbus RTU) 3: 8, O, 1 (Modbus RTU) 4: 8, N, 2 (MODBUS ASCII) 5: 8, N, 1 (MODBUS ASCII) 6: 8, E, 1 (MODBUS ASCII) 7: 8, O, 1 (MODBUS ASCII) 8: 7, N, 2 (MODBUS ASCII) 9: 7, N, 1 (MODBUS ASCII) 10: 7, E, 1 (MODBUS ASCII) 11: 7, O, 1 (MODBUS ASCII)	Default: 1 Min.: 0 Max.: 11

Parameter	Name	Description	Setting Range
E6-09	Communication Fault Detection Time	Sets the detection time for communication fault. 0: Disabled	Default: 0.0 s Range: 0.0 to 10.0 s
E6-10	Transmit Wait Time	Sets the wait time between sending and receiving data.	Default: 5ms Range: 0 to 65 ms
E6-11	Drive Operation During Communication Failure	0 : Display CE Alarm Only. Drive continues operation. 1 : Display CE Fault. Drive coasts to stop.	Default: 0 Range: 0, 1
E6-12	Frequency command memory function	0 : Disable 1 : Frequency command is memorized when power turn off	Default: 1 Range: 0, 1
E6-13	Value of frequency command	Sets the frequency command	Default: 0.00Hz Range: 0.00 to 400.00 Hz
Group P, Protections			
P1 : Motor Protection Function			
P1-00	Motor Protection Function Selection	0 : Disabled (Motor Overload Protection Disabled) 1 : General-Purpose Motor (Standard Motor) 2* : Drive Dedicated Motor (Constant Torque Range 1 : 10) 3 : Vector Motor (Constant Torque Range 1 : 100)	Default : 0 Range: 0 to 3
P1-01	Motor Overload Protection Time	Sets the time for the drive to shut down on motor overload.	Default: 1.0 minute Min.: 0.1 minutes Max.: 5.0 minutes
P1-05	Retained		

Parameter	Name	Description	Setting Range
P2 : Momentary Power Loss			
P2-00	Momentary Power Loss Operation Selection	0 : Disabled (Default) 1 : Recover if CPU Has Power	Default : 0 Range : 0, 1
P2-01	Minimum Baseblock (bb) Time	Sets the minimum baseblock time when power is restored right after a momentary power loss. This determines the time the drive waits for the residual voltage in the motor to dissipate. Increase this value if overcurrent or overvoltage occurs at the beginning of Speed Search and DC Braking	Default : 0.2-03 Min. : 0.1 s Max. : 5.0 s
P2-02	Uv (Undervoltage) Detection Delay Time	Sets the Delay time of undervoltage detection.	Default: 0ms Min.: 0 ms Max.: 1000 ms
P2-03	Uv Detection Level	Sets the voltage level of undervoltage detection.	Default: Determined by d1-00, o2-03 Min.: 150V Max.: 210V <3>
P2-05	Acceleration Time after Uv (Undervoltage)	Sets the time to reaccelerate to the set frequency command after power loss. When set to 0.0 s, the drive will accelerate to the previously active frequency according to the active acceleration time set by either of C1-00, C1-02	Default : 0.3 s Min. : 0.0 s Max. : 6000 s
P2-10	Automatic voltage regulation (AVR)	0 : AVR is disabled 1 : AVR is enabled 2 : Cancel AVR when decelerating	Default : 1 Min. : 0 Max. : 2
P3 : Stall Prevention			
P2-00	Momentary Power Loss Operation Selection	0 : Disabled 1 : Enabled the value set in P3-01. Acceleration stops when the output current exceeds the value set in P3-01. Acceleration continues when the output current drops 15% below the value set in P3-01.	Default : 0 Range : 0, 1

Parameter	Name	Description	Setting Range
P3-01	Stall Prevention Level during Acceleration	Sets the output current level to activate the Stall Prevention function during acceleration.	Default: 150% Min.: 0% Max.: 180
P3-02	Stall Prevention Limit during Acceleration	Sets the lower limit of Stall Prevention in the constant power range as a percentage of the drive rated output current.	Default : 50% Min. : 0 % Max. : 100 %
P3-03	Stall Prevention during Deceleration	The drive decelerates according to the set deceleration time 0 : Disabled 1 : Enabled (Without Braking Resistor) 2 : Overexcitation deceleration but no stall prevention 3 : Overexcitation deceleration includes stall Prevention	Default : 1 Range : 0, 1, 2, 3
P3-04	Stall Prevention Level during Deceleration	Sets the voltage level to activate the Stall Prevention function during deceleration.	Default: 395V Min.: 330V Max.: 410V <3>
P3-05	Stall Prevention during Run	0 : Disabled 1 : Enabled (Deceleration Time 1) 2 : Enabled (Deceleration Time 2)	Default: 1 Range: 0, 1, 2
P3-06	Stall Prevention Level during Run	Sets the current level to activate the Stall Prevention function during run.	Default: 150% Min.: 30% Max.: 180%
P3-07 ~ P3-10	Retained		
P4 : Frequency Detection			
P4-00	Frequency Detection Level	Sets the detection level and width for the multi-function output terminal.	Default : 30.0 Hz Min.: 0.0 Hz Max.: <5>
P4-01	Frequency Detection Width		Default : 2.0 Hz Min.: 0.1 Hz Max.: 25.5 Hz

Parameter	Name	Description	Setting Range
P4-02	Frequency Command Loss Detection Selection	Sets the drive operation when a frequency command loss is detected. 0 : Drive Stop 1 : Continue operation according to the setting in P4-03.	Default: 0 Range: 0, 1
P4-03	Frequency Command at Frequency Command Loss	Sets the frequency command level at which the drive runs when detecting a frequency command loss and when L4-02 is set to 1. Sets the value as a percentage of the maximum output frequency set in d1-02.	Default : 80% Min. : 0.0 % Max. : 100.0 %
P4-04	Frequency Command Loss Detection Time	When the frequency command falls below 90% of the command within this detection time, the frequency command loss will be detected.	Default : 20ms Min. : 20 ms Max. : 400 ms
P4-05	Mechanical brake release frequency	Set the mechanical brake release frequency	Default: 0 Hz Min.: 0.0 Hz Max.: 20.00 Hz
P4-06	Mechanical braking frequency	Set the mechanical braking frequency	Default : 0 Hz Min. : 0.0 Hz Max. : 20.00 Hz
P5 : Fault Restart			
P5-00	Number of Auto Restart Attempts	Sets the number of times to automatically attempt to restart the drive when detecting GF, OVA, OVD, OVC, OCA, OCD, OCC, OH, OL1, OL2, OT1, OT2, PF and LF1.	Default : 0 Min. : 0 Max. : 10
P5-01	Auto Restart Fault Output Operation	0 : Fault Output Disabled 1 : Fault Output Enabled	Default: 0 Range: 0, 1
P5-02	Fault Restart Interval Time	Sets the amount of time between restart attempts.	Default: 10.0 s Min.: 0.5 s Max.: 600.0 s
P6 : Overtorque / Undertorque Detection			
P6-00	Overtorque / Undertorque Detection Selection 1	Sets the operation when the motor current or torque exceeds the P6-01 level for longer than the time set to P6-02. 0 : Disabled 1 : Overtorque Alarm at Speed Agree	Default : 0 Range : 0 to 8

Parameter	Name	Description	Setting Range
		2 : Overtorque Alarm at Run 3 : Overtorque Fault at Speed Agree 4 : Overtorque Fault at Run 5 : Undertorque Alarm at Speed Agree 6 : Undertorque Alarm at Run 7 : Undertorque Fault at Speed Agree 8 : Undertorque Fault at Run	
P6-01	Overtorque / Undertorque Detection Level 1	Sets the level for overtorque/undertorque detection 1.	Default: 150% Min.: 0 % Max.: 300 %
P6-02	Overtorque / Undertorque Detection Time 1	Sets the time for overtorque/undertorque detection 1.	Default: 0.1 s Min.: 0.0 s Max.: 10.0 s
P7 : Drive Protection			
P7-00	Input Phase Loss Protection	Enables or disables the input phase loss detection. 0 : Disabled 1 : Enabled	Default : 1 Range : 0, 1
P7-01	Output Phase Loss Protection	Sets the output phase loss detection. 0 : Disabled 1 : Enabled when One Phase is Lost 2 : Enabled when Two Phases are Lost	Default: 0 Range: 0, 1, 2
P7-02	Retained		
P7-03	Heatsink Cooling Fan Operation <6>	Sets the heatsink cooling fan operation. 0 : Enabled when drive is running 1 : Enabled when power supply is On 2 : Enabled when the heatsink temperature reaches the limit.	Default: 0 Range: 0, 1, 2
P7-04	Heatsink Cooling Fan Off-Delay Time	When P7-04=0, sets the cooling fan off-delay time that the drive waits to disabled the cooling fan after run command is released.	Default : 60 s Min. : 0 s Max. : 300 s
P7-07	Retained		

Parameter	Name	Description	Setting Range
P7-09	Selection OL Decline curve	P7-09 sets the OL2 decrement time to shorten the function (the power will be stored and will be initialized). 0 : Regression from 100% to 0% takes 4 minutes (preset value). 1 : 100%, 400V is 7 minutes, 200V is 10 minutes: 0 ~ 90%, linear processing (according to 8000 OL2 decreasing curve).	Default : 1 Range : 0,1
P7-11	High Current Alarm Setting	Sets the High Current Alarm (HCA) when the output current is too high 0 : Disabled (No Alarm) 1 : Enabled (Alarm)	Default : 0 Range : 0, 1
P7-14	Standby precharge	Turn on/off standby precharge 0 : Close 1 : Open	Default : 0 Range : 0 to 1
Group n, Special adjustment function group			
n1 : Special Adjustment			
n1-00	Oscillation suppression (DEHUNTTING) Enables	0 : Turn Run 1 : Turn Off	Default: 1 Min.: 0 Max.: 1 Unit:-
n1-01	Oscillation suppression (DEHUNTTING) gain value setting	Oscillation suppression gain during speed-search	Default : 2.00 Min. : 0.00 Max. : 5.00
n3 : Excessive Deceleration			
n3-04	Overexcitation gain	Set the gain applied to V / F mode during overexcitation deceleration (P3-03 = 2, 3)	Default : 1.10 Min. : 1.00 Max. : 2.50
n3-06	Overexcitation suppression current value	Setting the drive will begin to reduce the output current level of the overexcitation gain to prevent excessive motor slip during overexcitation deceleration. Set to the percentage of the rated current of the inverter	Default : 100 Min. : 0 Max. : 150

Parameter	Name	Description	Setting Range
Group o, Keypad Function Settings			
o1 : Display Setting			
o1-00	Frequency Command Setting/Display Unit	0: Use units of 0.01 Hz 1: Use units of 0.01% (100% as maximum output frequency) 2: Use units of rpm 3: Any unit (details are set by o1-02, o1-03)	Default : 0 Range : 0 to 3
o1-02	User-Defined Frequency Command Setting/Display	1 ~ 9999	Default : o1-00 Min. : 1 Max. : 9999
o1-03	Frequency Command Setting/Display Decimal Places	0 ~ 3	Default : o1-00 Min. : 0 Max. : 3
o1-04	Main screen display selection	0: frequency command 1: output current 2: DC bus voltage 3: output voltage 4: Motor speed 5: AI1 (Percentage)	Default: 0 Min.: 0 Max.: 5 Unit: -
o2 : Multi-Function Selection			
o2-01	STOP Key Function Selection	Enables or disables the STOP key on the keypad when the drive is controlled from a remote source. 0: Disabled 1: Enabled The STOP key always stops drive operation even if the command source is not set to the keypad.	Default: 1 Range: 0, 1
o2-02	Retained		
o2-03	Drive Capacity Selection <2>	Set this parameter after replacing the terminal block or drive modules.	Default: <2> Determined by drive capacity

Parameter	Name	Description	Setting Range
o2-04	ENTER Key Function During Frequency Command Setting	0 : ENTER Key Required 1 : ENTER Key Not Required 2 : ENTER Key Not Required	Default: 0 Range: 0 ~ 2
o2-05	Retained		
o2-06	Operation Direction at Power Up when Using Keypad	0 : Forward 1 : Reverse This parameter is enabled only when the keypad is selected as the Run command source.	Default : 0 Min. : 0 Max. : 1
o4 : Maintenance Settings			
o4-00	Cumulative Operation Time Setting	Sets the initial value by 1 hours to start keeping track of cumulative operation time.	Default : 0 h Min. : 0 Max. : 9999
o4-06	U2 Reset Setting	Resets the data for U2-ax.: 9999 (Information) as these data will not be reset by A1-03 (Reset). 0 : Disabled 1 : Enabled	Default : 0 Range : 0, 1
Group t, Auto-Tuning			
t1 : IM Motor Auto-Tuning			
t1-01	Auto-Tuning Method Selection	0 : Rotational Auto-Tuning 1 : Stationary Auto-Tuning	Default : 0 Min.: 0 Max.: 1
t1-02	Motor Output Power	Sets the motor rated output power in kW units. Note: 1HP (Horse Power) = 0.746kW	Default: Determined by o2-03 Min.: 0.00 kW Max.: 650.00 kW
t1-03	Motor Rated Voltage	Sets the motor rated voltage according to the motor nameplate.	Default : 200.0 V Min.: 0.0 V Max.: 255.0 V <3>
t1-04	Motor Rated Current	Sets the motor rated current according to the motor nameplate.	Default : <2> Min.: 10% of drive rated current Max.:200% of drive rated current

Parameter	Name	Description	Setting Range
t1-05	Motor Base Frequency	Sets the motor base frequency according to the motor nameplate.	Default : 50.0 Hz Min.: 0.0 Hz Max.: 400.0 Hz
t1-06	Number of Motor Poles	Sets the number of motor poles according to the motor nameplate.	Default : 4 Min.: 2 Max.: 48
t1-07	Motor Base Speed	Sets the motor base speed according to the motor nameplate.	Default: 145(x10rpm) Min.: 0 rpm Max.: 2400(x10rpm)
t1-09	Motor No-Load Current (Stationary Auto-Tuning)	Sets the no-load current for the motor. After the motor output power and rated current are set in t1-02 and t1-04, this parameter will automatically display the no-load current of a standard motor. The no-load current must be entered according to the motor test report.	Default: Determined by o2-03 Min.: 0.0 A Max.: t1-04
t1-12	Motor Auto-Tuning Setting	Enables or disables Auto-Tuning when A1- 02=0 to 3 0 : Disabled 1 : Enabled	Default 0 Min.: 0 Max.: 1
Group F, Optional Function Group			
F1 : Pump function			
F1-00	User pressure sensor specification setting	According to the pressure sensor specification (max. feedback voltage or pressure value corresponding to feedback current)	Default: 10.0 Min.: 0.0 Max.: 10.0 Unit: 0.1bar (kg/cm ²)
F1-01	(Switch mode) pressure operation	In the switch mode, the inverter automatically controls the pump to start or stop according to the set value. *When the set value is greater than the target value, the stop level is the target pressure, and the starting level is 0.	Default: 0.3 Min.: 0.1 Max.: 10 Unit: 0.1bar (kg/cm ²)

Parameter	Name	Description	Setting Range
F1-02	(Switch mode) detection time setting	Set the percentage of time and calculate the detection time to determine whether to enter the switch mode. Set value 0: Switch mode function is OFF.	Default: 40 Min.: 0 Max.: 100 Unit: 1%
F1-03	(Water detection) pressure rise level	Raise a specified pressure level to detect if water is currently being used.	Default: 0.2 Min.: 0 Max.: 1.0 Unit: 0.1bar (kg/cm ²)
F1-04	(Water detection) pressure rise time "limit"	Set the lifting time "limit" of F1-03 (pressure rise level) to detect whether water is currently used. Set value 0: This function is OFF	Default: 0 Min.: 0 Max.: 25 Unit: 0.1 sec
F1-05	(Water detection) pressure rise interval	Set the time interval of F1-03 (pressure rise level) to detect whether water is currently used. Set value 0: Water detection function is OFF	Default: 35 Min.: 0 Max.: 250 Unit: sec
F1-06	(Water detection) inverter standby (sleep) level	When the inverter running frequency is lower than the set value, it will automatically decelerate to 0 Hz and enter the standby (sleep) state.	Default: 5Hz Min.: 0 Max.: 60 Unit: 1Hz
F1-07	PID control recovery level setting	When the inverter is in the standby (sleep) state, when the pressure drops to the recovery level, the inverter starts and enters the PID control mode. Recovery level: Set pressure (SV) F1-07 set value. *When the set value is greater than the target pressure, the recovery level is 0Hz.	Default: 0.3 Min.: 0.0 Max.: 10.0 Unit: 0.1bar (kg/cm ²)
F1-08	PID steady state tolerance	Provide error range to determine whether PID control has reached stability.	Default: 0.1 Min.: 0.1 Max.: 0.5 Unit: 0.1bar (kg/cm ²)
F1-09	(Water shortage detection) pressure level	100% is the target pressure, set value 0 is OFF.	Default: 40 Min.: 0 Max.: 100 Unit: 1%

Parameter	Name	Description	Setting Range
F1-10	(Water shortage detection) current level	Set the current level to detect if the pump is in a water shortage state. 100% is the rated current of the motor, set value 0 is OFF.	Default: 0 Min.: 0 Max.: 100 Unit: 1%
F1-11	(Water shortage detection) detection time	Set F1-09 pressure and F1-10 current detection time.	Default: 60 Min.: 0 Max.: 250 Unit: 1 sec
F1-12	(Fault restart) downtime interval	Shutdown time of the pump in the absence of water.	Default: 10.0 Min.: 0.5 Max.: 600.0 Unit: 0.1 sec
F1-13	(Fault restart) restart function selection	The way the pump is started again in the absence of water: 0 : FBPL warning flashes, does not jump off 1 : FBPL fault trips stop, press RESET to restart 2 : FBPL fault trips stop, re-power and restart 3 : FBPL fault trip stop, waiting F1-12 sets the interval time, it automatically restarts. After the restart is completed, you must re-power on the reply.	Default: 10.0 Min.: 0.5 Max.: 600.0 Unit: 0.1 sec
Group U, Monitor Settings			
U1 : Status Monitors			
U1-00	Control Method	0 : Open-Loop V/F Control 2 : Sensorless Voltage Vector Control (SVVC) (Open-Loop)	-
U1-01	Frequency Command	Displays the frequency command. (Display units are defined by o1-00)	-
U1-02	Output Frequency	Displays the output frequency. (Display units are defined by o1-00)	-
U1-03	Output Current	Displays output current.	0.01A
U1-04	Motor Speed	Displays the motor speed.	-
U1-05	Output Voltage Command	Displays the drive output voltage command.	0.1V

Parameter	Name	Description	Setting Range
U1-06	Main circuit DC Voltage	Displays the main circuit DC voltage.	0.1V
U1-07	Output Power	Displays the internal output power calculated by the drive.	0.001kW
U1-08	(water pump function) display feedback/set pressure at the same time	display feedback/set pressure	0.1bar/0.1bar
U1-09	Input Terminal Status	Displays the status of the input terminal. U1-09=C1111111: The following indicate each digit from right to left. 1 : Digital Input 1 (S1 enabled) 1 : Digital Input 2 (S2 enabled) 1 : Digital Input 3 (S3 enabled) 1 : Digital Input 4 (S4 enabled) 1 : Digital Input 5 (S5 enabled) 1 : Digital Input 6 (S6 enabled)	-
U1-10	Output Terminal Status	Displays the status of the output terminal. U1-10=1 Multi-Function Terminal Output (terminal R1A/R1B-R1C)	-
U1-11	Drive Operation Status	Displays the status of the drive operation. U1-11=11111111 The following indicate each digit from right to left. 1 : During Run 1 : During Zero Speed Holding 1 : During Reverse 1 : During Fault Reset Signal Input 1 : During Speed Agree 1 : Drive Ready 1 : During Alarm Detection 1 : During Fault Detection	-
U1-12	Terminal A1 Input Voltage	Displays the terminal A1 input voltage.	0.1%

Parameter	Name	Description	Setting Range
U1-16	Software Version	Displays the software version.	-
U1-17		Display the date code	-
U1-19 <7>	Communication card software version	Communication card software version	-
U1-20	(water pump function) display setting pressure	Display the feedback pressure	0.1bar
U1-21	(water pump function) display setting pressure	Display the setting pressure	0.1bar
U2 : Fault Information			
U2-00	Current Fault	Displays the current fault.	-
U2-01	1 st Most Recent Fault	Displays the first most recent fault.	-
U2-02	2 nd Most Recent Fault	Displays the second most recent fault.	-
U2-03	3 rd Most Recent Fault	Displays the third most recent fault.	-
U2-04	4 th Most Recent Fault	Displays the fourth most recent fault.	-
U2-05	Frequency Command at 1 st Most Recent Fault	Displays the fourth most recent fault.	-
U2-06	Output Frequency at 1 st Most Recent Fault	Displays the output frequency at the first most recent fault.	-
U2-07	Output Current at 1 st Most Recent Fault	Displays the output current at the first most recent fault.	0.01A
U2-08	Motor Speed at 1 st Most Recent Fault	Displays the motor speed at the first most recent fault.	-

Parameter	Name	Description	Setting Range
U2-09	Output Voltage command at 1 st Most Recent Fault	Displays the output voltage command at the first most recent fault.	0.1V
U2-10	Main Circuit DC Voltage at 1 st Most Recent Fault	Displays the main circuit DC voltage at the first most recent fault.	0.1V
U2-13	Input Terminal Status at 1 st Most Recent Fault	Displays the input terminal status at the first most recent fault. (Same status display as U1-09)	-
U2-14	Output Terminal Status at 1 st Most Recent Fault	Displays the output terminal status at the first most recent fault. (Same status display as U1-10)	-
U2-15	Operation Status at 1 st Most Recent Fault	Displays the operation status at the first most recent fault. (Same status display as U1-11)	-
U2-17	Cumulative Operation Time at 1st Fault	Displays the cumulative operation time when the first fault occurred	1h
U2-18	Cumulative Running Time at 1st Fault	Displays the cumulative running time when the first fault occurred	1h
U2-19	Frequency Command at 2 nd Most Recent Fault	Displays the frequency command at the second most recent fault.	-
U2-20	Output Frequency at 2 nd Most Recent Fault	Displays the output frequency at the second most recent fault.	-
U2-21	Output Current at 2 nd Most Recent Fault	Displays the output current at the second most recent fault.	0.01A

Parameter	Name	Description	Setting Range
U2-22	Motor Speed at 2 nd Most Recent Fault	Displays the motor speed at the second most recent fault.	0.1 rpm
U2-23	Output Voltage command at 2 nd Most Recent Fault	Displays the output voltage command at the second most recent fault.	0.1V
U2-24	Main Circuit DC Voltage at 2 nd Most Recent Fault	Displays the main circuit DC voltage at the second most recent fault.	0.1V
U2-27	Input Terminal Status at 2 nd Most Recent Fault	Displays the input terminal status at the second most recent fault. (Same status display as U1-09)	-
U2-28	Output Terminal Status at 2 nd Most Recent Fault	Displays the output terminal status at the second most recent fault. (Same status display as U1-10)	-
U2-29	Operation Status at 2 nd Most Recent Fault	Displays the operation status at the second most recent fault. (Same status display as U1-11)	-
U2-31	Cumulative Power On Time at 2nd Fault	Displays the cumulative Power On Time when the second fault occurred	1h
U2-32	Cumulative Operation Time at 2nd Fault	Displays the cumulative operation time when the second fault occurred	1h
U2-33	Current Alarm	Displays the current alarm.	-
U2-34	1 st Most Recent Alarm	Displays the first most recent alarm.	-
U2-35	2 nd Most Recent Alarm	Displays the second most recent alarm.	-
U2-36	3 rd Most Recent Alarm	Displays the third most recent alarm.	-

Parameter	Name	Description	Setting Range
U2-37	4 th Most Recent Alarm	Displays the fourth most recent alarm.	-
U3 : Maintenance Monitors			
U3-00	Cumulative Drive Operation Time	Displays the cumulative operation time for the drive.	1h
U3-02	Cumulative Drive Operation Time	Displays the cumulative operation time for the drive. The initial value is determined by o4-00. Keeping track of time from run or power up is determined by o4-01. The maximum number displayed is 9999, after which the value will be counted from 0.	1h
U3-06	Heatsink temperature	Display the temperature of heatsink	1°C
U3-07	LED Check	Lights all segments of the LED to verify that the display is working properly	-
U3-10	Peak Hold Current	Displays the peak current value during operation	0.01A
U3-11	Peak Hold Output Frequency	Displays the output frequency when the peak current displayed in U3-10 occurred.	-
U3-12	Motor Overload Estimate (oL1)	Displays the value of the motor overload detection accumulator. An oL1 will be triggered when reaching 100%.	1%
U3-13	Frequency Command Source	Displays the source for the frequency command as XY-nn. X: Command Used 1: Command 1 Y-nn: Frequency Command Source 0-01: Keypad 1-01: Analog input (Terminal AI 1) 2-02 to 2-16: Multi-step speed command 2-17: Jog frequency command 3-01: PID frequency command 4-01: Terminal UP/DOWN 5-01: Modbus communication	-

Parameter	Name	Description	Setting Range
U3-14	Run Command Source Selection	Displays the source for the frequency command as XY-nn. XY-nn=00-00 : Local X : Command Used 1 : Command 1 Y-nn : Command Source 0-00 : Keypad 1-00 : Control Circuit Terminal (Sequence Control Input) 2-00 : Modbus communication	-
U3-17	Drive Overload Estimate (oL2)	Displays the value of the drive overload detection accumulator. An oL2 will be triggered when reaching 100%.	1%
U4 : PID Monitors			
U4-00	PID Feedback	Displays the PID feedback value as a percentage of the maximum output frequency.	0.01%
U4-01	PID Input	Displays the PID input value as a percentage of the maximum output frequency.	0.01%
U4-02	PID Output	Displays the PID output value as a percentage of the maximum output frequency.	0.01%
U4-03	PID Target	Displays the PID target value as a percentage of the maximum output frequency.	0.01%
U4-08	PID Output 2	Displays the PID output 2 value as a percentage of the maximum output frequency.	0.01%

<1> The default is determined by the drive capacity and control method.

<2> Refer to user manual for details. <https://www.bharatbijlee.com/drives-automation/>

<3> Double the value for 440V class AC drives.

<4> The parameter can be set during run.

<5> The upper limit is determined by d1-02 and L2-00 settings.

<6> Contact the Bharat Bijlee / Drives Sales Partner for any malfunction.

<7> This functional software version V1.40 open.

*means under development.

Chapter 6 | Troubleshooting

6.1 Alarm and Fault Displays

Table 6.1 Alarm and Fault Displays, Causes, and Possible Solutions

Keypad Display	Fault Name	Cause	Possible Solution
EFO	Retain		
EF1 to EF6	External Fault (Input Terminal S1 to S6)	<ol style="list-style-type: none"> 1. An external device tripped an alarm 2. Incorrect wiring 3. Multi-function input wiring is not correct 	<ol style="list-style-type: none"> 1. Remove the cause of the external fault then reset the multi-function input. 2. Confirm if the signal lines is properly connected to the terminals assigned for external fault detection (E1-□□= 23 to 38) 3. Confirm if E1-□□=23 to 38 is set to the unused terminals.
FbH	<p>PID Feedback High</p> <p>PID feedback input is greater than the detection level set to b5-22 for longer than the detection time set to b5-23</p>	<ol style="list-style-type: none"> 1. b5-22 and b5-23 inappropriate setting 2. PID feedback wiring incorrect 3. Feedback sensor malfunction 4. Feedback input circuit malfunction 	<ol style="list-style-type: none"> 1. Confirm b5-22 and b5-23 settings 2. Correct the wiring 3. Replace the sensor if it is damaged 4. Replace the PCB or drive. Contact the local distributor.
FbL	<p>PID Feedback Low</p> <p>When the PID feedback detection is enabled in b5- 11, a FbL will be triggered while the PID feedback falls below the level set to b5- 12 for longer than the time set to b5-13.</p>	<ol style="list-style-type: none"> 1. Inappropriate setting in b5-12 and b5-13 2. Incorrect PID feedback wiring 3. Feedback sensor malfunction Incorrect feedback input circuit 	<ol style="list-style-type: none"> 1. Correct b5-12 and b5-13 settings 2. Correct the wiring 3. Replace the sensor if it is damaged 4. Contact the local distributor to replace the board or the drive.

Keypad Display	Fault Name	Cause	Possible Solution
oH	Heatsink Overheat Heatsink temperature over 95°C	<ol style="list-style-type: none"> 1. Ambient temperature is too high 2. Internal cooling fan stopped operating 3. Bad air flow due to insufficient room. 	<ol style="list-style-type: none"> 1. Check the temperature surrounding the drive <ol style="list-style-type: none"> a. Improve the air flow inside the enclosure panel b. Install an air conditioner or fan to cool the environment c. Remove any possible source of heat 2. Measure the output current <ol style="list-style-type: none"> a. Reduce the load b. Lower setting in C6 -00 (Carrier Frequency Option) 3. Replace the cooling fan
oH1	Motor Overheat The temperature signal from motor temperature sensor via the multi- function analog input (E3-01=20) exceeded the overheat detection level of the drive.	<ol style="list-style-type: none"> 1. Fault on the machinery (e.g., machinery is locked up) 2. Motor overheat 	<ol style="list-style-type: none"> 1. Check the machinery status 2. Check the load, acceleration / deceleration time and cycle time <ol style="list-style-type: none"> a. Reduce the load. b. Increase the C1-00 to C1-07 (Acc./Dec. Time) settings c. Adjust d1-02 to d1-11 (V/F Characteristics)
ot1	Overtorque Detection 1 The current has exceeded the torque level set to P6-01 for longer than the time set to P6-02	<ol style="list-style-type: none"> 1. Incorrect parameter settings 2. Malfunction on machinery 	<ol style="list-style-type: none"> 1. Reset P6-01 and P6-02 2. Check machinery and load status
ov	Overvoltage Voltage in the DC bus exceeded the overvoltage detection level 1.200 V class: 410 V 2.400 V class: 820 V	<ol style="list-style-type: none"> 1. Drive input power has surge voltage entering 2. Machinery output short circuit 3. Ground fault in the output circuit causes the DC bus capacitor to 	<ol style="list-style-type: none"> 1. Install a DC link choke Voltage surge can result from a thyristor convertor and phase advancing capacitor using the same input power supply 2. Check the motor power cable, relay terminals and motor terminal box

Keypad Display	Fault Name	Cause	Possible Solution
	(740 V when d1-01 < 400)	overcharge 4. Electrical signal interference causes drive malfunction	3. Correct grounding shorts and reapply power 4. Check the solutions for interference suppression »Check the control circuit lines, main circuit lines and grounding wiring. »If the MC is the source of interference, connect a suppressor to it. 5. Reconnect the cable 6. Correct the wiring
Uv	Undervoltage 1. Voltage in the DC bus fell below the undervoltage detection level (P2-03) 2. 200 V class: 190 V 3. 400 V class: 380 V (350 V when d1- 01 < 400)	1. Input power phase loss 2. Loose wiring terminals of drive input power 3. Problem with the voltage from the drive input power 4. The drive main circuit capacitors are weakened. 5. The contactor or relay on the soft- charge bypass circuit is damaged	1. Correct the drive input power wiring 2. Tighten the terminals 3. Check the voltage a. Adjust the voltage according to the drive input power specifications b. Check the main circuit magnetic contactor if there is no problem with the power supply 4&5. Turn on and turn off the power to see if any problem occurs Replace either the entire drive or the control board if the problem continues to occur. Contact the local distributor for more information.
Ut1	Undertorque Detection 1 The current has dropped below the torque detection level set to P6-01 for longer than the time set to P6-02	1. Incorrect parameter settings 2. Malfunction on machinery side. Ex, the machinery is locked up	1. Reset P6-01 and P6-02 2. Ensure there is no problem on the machinery side.

Keypad Display	Fault Name	Cause	Possible Solution
bb	Baseblock Drive output interrupted by an external baseblock signal	An external baseblock signal was input via one of the multi-function input terminals (S1 to S6)	Check baseblock signal input timing and external sequence
oH2	Drive Overheat Warning Drive Overheat Warning input via a multi-function input terminal (S1to S6) when E1-□□= 40	An overheat warning in the drive was triggered by an external device	1. Search the device which caused the overheat warning. Remove the cause of the problem. 2. Reset Drive Overheat Warning input at the assigned multi-function input terminal (S1 to S6)
HCA	Current Alarm Drive current exceeded the level of over current warning (150% of the rated current)	1. The load is too heavy 2. Deceleration and acceleration times are too short 3. The drive is attempting to run a motor greater than the maximum allowable capacity, or a special-purpose motor is being used 4.The current level went up because of Speed Search while attempting to perform a fault restart or after a momentary power loss	1. Reduce the load or use a drive of higher rating 2. Calculate the torque required during acceleration and the inertia »Take the following steps if the torque level is not right for the load · Increase the settings for acceleration and deceleration time (C1-00 to C1-03) · Use a drive of higher rating 3. Check the motor capacity · Make sure the motor capacity is right for the drive rating. 4. During a momentary power loss or an attempt to reset a fault, the alarm is displayed. However, there is no need to take any action because the fault display will disappear shortly

Keypad Display	Fault Name	Cause	Possible Solution
DNE	Driver Enable	1. Multi-function contact input is set to 69/169, but the contact input status is incorrect 2. The multi-function contact input is incorrect	1. Multi-function contact input is set to 69 and switched on. 2. Multi-function contact input is set to 169 and switched off
AnL	Simulation A2 input signal is lost	1. Simulation A2 input signal is lost	1. Check the simulation signal wiring 2. Check the E3-10 parameter settings
ES	Emergency Stop	1. Emergency stop is turned on (P2-11) before the power off, when the DC bus voltage is lower than P2-06 2. Multi-function contact input is set to 21/121, but the contact input is switched on	1. Turn off the emergency stop function P2-11, or adjust P2-06 settings Level 2. Confirm the multi-function contact input function set and terminal status

6.2 Fault Detection

Table 6.2 Fault Displays, Causes, and Possible Solution

Keypad Display	Fault Name	Cause	Possible Solution
GF	Ground Fault	Output power cable is damaged	Check and replace output power Cable
oVA、 oVd、 oVC、 oVAH、 oVdH、 ovCH	Overvoltage (Acceleration, Deceleration and Constant Speed) The main circuit DC voltage exceeded the overvoltage detection level	1. Regenerative energy is flowing from the motor into the drive because the deceleration time is too short 2. The motor overshoot the speed reference because the	1. Increase the deceleration time settings (C1-01 and C1-03) » Install a braking unit » Set P3-03 (Stall Prevention during Deceleration) to 1 (Enabled)(default is 1) 2. Confirm if overvoltage alarm oVA or oVC was triggered during sudden drive acceleration.

Keypad Display	Fault Name	Cause	Possible Solution
	200V class: 410V 400 V class: 820 V	acceleration time is too short 3. Excessive braking load 4. Surge voltage entering from the drive input power 5. Motor short-circuited Ground fault current charges the drive main circuit capacitor. 6. Improper parameter settings for Speed Search (including Speed Search after a fault restart and after a momentary power loss) 7. Drive input voltage is too high 8. The braking transistor or braking resistor are wired incorrectly 9. PG cable is disconnected 10. PG cable wiring is incorrect 11. PG encoder wiring has interference of electrical signal 12. Electrical signal interference causes the drive malfunction 13. Incorrect inertia setting of the load 14. Motor hunting occurs	» Increase the acceleration time » Use S-curve deceleration and acceleration times and increase the value set to C2-01 (S-curve at acceleration end) 3.Thyristor convertor and phase advancing capacitor using the same input power supply might cause a voltage surge 4. Check the motor power cable, relay terminals and motor terminal box » Correct grounding shorts and reapply power 5. Adjust parameter settings for Speed Search (group b3) »Proceed Auto-Tuning for line-to-line resistance 6. Check the voltage »Lower drive input power voltage within the range listed in the drive specifications 7. Check the wiring of the braking resistor and braking unit »Correct the wiring 8. Tighten the terminal or replace the damaged cable 9. Correct the wiring 10. Check the solutions for interference suppression

Keypad Display	Fault Name	Cause	Possible Solution
oCA, oCd, oCC	Overcurrent (Acceleration, Deceleration and Constant Speed)	<ol style="list-style-type: none"> 1. The motor insulation is damaged or the motor is overheated 2. Grounding problem caused by damaged motor cable 3. The drive is damaged 4. The load is too heavy 5. Settings for acceleration or deceleration time is too short 6. The drive is running a special purpose motor or a motor larger than the drive rated capacity 7. A magnetic contactor (MC) on the output side of the drive has turned on or off 8. V/F set incorrectly 9. Excessive torque compensation 10. Electrical signal interference causes drive malfunction 11. Overexcitation gain is set too high 12. Run command was applied while motor was coasting 13. Incorrect motor code 14. The motor does not match the drive control method 15. The motor cable is too long 	<ol style="list-style-type: none"> 1. Check the insulation resistance 2. Check the motor power cable 3. Check the resistance between the cable and the terminal. 4. Short circuit on drive output side or grounding causes register damage. 5. Measure the current flowing into the motor 6. Check the motor capacity 7. Calculate the torque required during acceleration according to the load inertia and acceleration time. If the required torque is insufficient, check the motor capacity. 8. Install a sequence controller to ensure the MC does not open or close when the drive is outputting voltage. 9. Check the ratios between the frequency and voltage set by V/F. 10. Adjust d1-02 to d1-11 (or d1-13 to d1-22 for motor 2) 11. Check the amount of torque compensation 12. Find out possible solutions to suppress the electrical signal interference 13. Check if the fault occurs frequently with overexcitation function operation 14. Enable Speed Search via multi- function input terminal 15. Check the control method (A1- 02) 16. Use a larger drive

Keypad Display	Fault Name	Cause	Possible Solution
SC、 SC1、 SC2、 SC3	IGBT Fault or Output Short Circuit	1. Motor has been damaged due to the motor insulation weakened or overheat 2. The cable is damaged 3. Hardware fault 4. The drive is damaged	1. Replace the motor or check the motor insulation resistance 2. Repair any short circuits and check the motor power cable
EFO	Retain		
EF1 to EF6	External Fault (Input Terminal S1 to S6)	1. An external device tripped an alarm 2. Incorrect wiring 3. Multi-function input wiring is not correct	1. Remove the cause of the external fault then reset the multi-function input. 2. Confirm if the signal lines is properly connected to the terminals assigned for external fault detection (E1-□□= 23 to 38) 3. Confirm if E1-□□=23 to 38 is set to the unused terminals.
O(P)E1 7	Improper setting of motor rated speed	Motor rated speed setting over than motor synchronous speed	1. Correctly set the motor base frequency and motor number 2. Correctly set the rated motor speed Motor synchronous speed = 120 base frequency / motor pole count
oH	Heatsink Overheat Heatsink temperature over 95 °C	1. Ambient temperature is too high 2. Internal cooling fan stopped operating 3. Bad air flow due to insufficient room.	1. Check the temperature surrounding the drive a. Improve the air flow inside the enclosure panel b. Install an air conditioner or fan to cool the environment c. Remove any possible source of heat 2. Measure the output current a. Reduce the load b. Lower setting in C6-00 (Carrier Frequency Option) 3. Replace the cooling fan

Keypad Display	Fault Name	Cause	Possible Solution
oH1	<p>Motor Overheat 1</p> <p>The temperature signal from motor temperature sensor via analog input terminal A1 (E3-01=20) exceeded the overheat detection level of the drive.</p>	<ol style="list-style-type: none"> 1. Incorrect motor temperature input (terminal MT) wiring 2. Fault on the machinery (e.g., machinery is locked up) 3. Motor overheat 	<ol style="list-style-type: none"> 1. Check the load, acceleration / deceleration time and cycle time <ol style="list-style-type: none"> a. Reduce the load b. Increase C1-00 to C1-03 (Acc./Dec. Time) settings 2. Adjust d1-02 to d1-09 (V/F Characteristics) <p>Note : If the d1-02 and d1-09 are set too low, the tolerance at low speed will be reduced.</p> 3. <ol style="list-style-type: none"> a. Check the setting for motor rated current. Set d1-00 as per the data written on the motor plate. b. Check if the motor cooling is working properly.
oL1	Motor Overload	<ol style="list-style-type: none"> 1. The load is too heavy 2. The acceleration and deceleration times are too short 3. The motor is driven below the rated speed with a high load 4. Incorrect setting in P1-00 (Motor Protection Function Selection) when running a special motor 5. The voltage determined by the V/F is too high 6. d2-00 (Motor Rated Current) setting incorrect 7. The base frequency is set too low 8. Use one drive to run multiple motors 9. The electrical thermal protection characteristics do not match the motor overload characteristics. 10. The electrical 	<ol style="list-style-type: none"> 1. Check loading capacity <ul style="list-style-type: none"> » Reduce the load 2. Confirm acceleration and deceleration times <ul style="list-style-type: none"> » Increase C1-00 to C1-03 parameter settings 3. <ul style="list-style-type: none"> » Reduce the load » Increase the speed » Either increase the motor capacity or use a special-purpose motor if the motor needs to operate at low speeds 4. Set P1-00 to 2. 5. Adjust d1-02 to d1-09 settings (V/F Characteristics) <p>Note: If d1-02 to d1-09 settings are too low, load tolerance at low speeds will be reduced</p> 6. Confirm the motor rated current <ul style="list-style-type: none"> » Set d2-00 (Motor Rated Current) according to the motor nameplate 7. Confirm the rated frequency showed on the motor nameplate

Keypad Display	Fault Name	Cause	Possible Solution
		<p>thermal relay operates at the wrong level</p> <p>11. Motor overheated by overexcitation operations</p> <p>12. Speed Search related parameters are set incorrectly</p> <p>13. Power supply phase loss causes output current oscillation.</p>	<p>»Set d1-04 (Base Frequency) according to the motor nameplate</p> <p>8. Set P1-00 (Motor Protection Function Selection) to 0 (Disabled) and install a thermal relay to each motor</p> <p>9. Confirm characteristics of the motor</p> <p>»Set P1-00 (Motor Protection Function Selection) correctly</p> <p>»Install an external thermal relay</p> <p>10. Set the the motor rated current according to the motor plate.</p> <p>11. Adjust parameters related to Speed Search</p> <p>»Adjust the b3-01 (Speed Search Operation Current) setting</p> <p>12. Check the power supply for phase loss</p>
oL2	Drive Overload	<p>1. The load is too heavy</p> <p>2. The acceleration and deceleration times are too short</p> <p>3. The voltage determined by the V/F is too high</p> <p>4. The drive capacity is too small</p> <p>5. The motor is driven below the rated speed with a high load</p> <p>6. Torque compensation is too high</p> <p>7. Speed Search related parameters are set incorrectly</p> <p>8. Power supply phase loss causes output current oscillation</p>	<p>1. Check loading capacity</p> <p>» Reduce the load</p> <p>2. Confirm acceleration and deceleration times</p> <p>»Increase C1-00 to C1-03 parameter settings</p> <p>3. Adjust d1-02 to d1-09 settings (V/F Characteristics)</p> <p>Note: If d1-02 to d1-09 settings are too low, load tolerance at low speeds will be reduced</p> <p>4. Use a larger drive</p> <p>5. »Reduce the load at low speed</p> <p>» Use a larger drive</p> <p>Set a lower value to C6-00 (Carrier Frequency)</p> <p>6. Check the torque compensation</p> <p>» Set a lower value to C3-00 (Torque Compensation Gain) until the current is decreased and the motor does not stall.</p>

Keypad Display	Fault Name	Cause	Possible Solution
			7. Adjust parameters related to Speed Search » Adjust b3-03 8. Check the power supply for phase loss
ot1	Overtorque Detection 1 The current has exceeded the torque level set to P6-01 for longer than the time set to P6-02	1. Incorrect parameter settings 2. Malfunction on the machinery side	1. Reset P6-01 and P6-02 2. Check machinery and load status
Ut1	Undertorque Detection 1 The current has dropped below the torque detection level set to P6-01 for longer than the time set to P6-02	1. Incorrect parameter settings 2. Malfunction on the machinery side	1. Reset P6-01 and P6-02 2. Ensure there is no problem on the machinery side.
Uv1	Undervoltage Detection 1 Voltage in the DC bus fell below the undervoltage detection level (P2-03) during run. · 200 V class: 190 V · 400 V class: 380 V	1. Input power phase loss 2. Loose wiring terminals of drive input power 3. Problem with the voltage from the drive input power 4. The drive main circuit capacitors are weakened. 5. The contactor or relay on the soft-charge bypass circuit is damaged	1. Correct the drive input power wiring 2. Tighten the terminals 3. Check the voltage a. Adjust the voltage according to the drive input power specifications b. Check the main circuit magnetic contactor if there is no problem with the power supply 4. Turn on and turn off the power to see if any problem occurs a. Replace either the entire drive or the control board if the problem continues to occur. Contact the local distributor for more information.

Keypad Display	Fault Name	Cause	Possible Solution
Uv2	Retain		
PF	<p>Input Phase Loss</p> <p>Drive input power has a large imbalance of voltage between phases or has an open phase (Detected when P7-00=1)</p>	<ol style="list-style-type: none"> 1. Phase loss in the drive input power 2. Drive input power terminals has a loose wiring 3. Drive input power voltage has an excessive fluctuation 4. The main circuit capacitors are impaired 	<ol style="list-style-type: none"> 1. Check wiring for errors in the main circuit drive input power »Correct wiring 2. Make sure the terminals are tightened correctly »Apply the tightening torque as showed in the manual 3. Confirm the voltage from the drive input power »Apply possible solutions for drive input power stabilization 4. Check drive input power. If drive input power seems normal but the alarm continues to occur, replace either the entire drive or the control board. Contact the local distributor for more information.
LF1	<p>Output Phase Loss</p> <p>Phase loss on the drive output side</p>	<ol style="list-style-type: none"> 1. The output cable is not connected 2. The motor winding is impaired 3. The output terminal is loose 4. The rated current of the motor being used is 5% less than the drive rated current 5. An output transistor is impaired 6. A single phase motor is activating 	<ol style="list-style-type: none"> 1. Check the errors for wiring then properly connect the output cable »Correct the wiring 2. Check the resistance which located between motor lines »If the winding is impaired, replace the motor 3. Use tightening torque which showed in the manual in order to fasten the terminal 4. Check motor capacities and the drive 5. The drive cannot run a single phase motor
FbH	PID Feedback High	<ol style="list-style-type: none"> 1. Incorrect parameter settings 2. Incorrect PID feedback wiring 3. Feedback sensor malfunction 	<ol style="list-style-type: none"> 1. Reset b5-22 and b5-23 2. Correct the wiring 3. Check the sensor

Keypad Display	Fault Name	Cause	Possible Solution
FbL	PID Feedback Low	<ol style="list-style-type: none"> 1. Incorrect parameter settings 2. Incorrect PID feedback wiring 3. Feedback sensor malfunction 	<ol style="list-style-type: none"> 1. Reset b5-12 and b5-13 2. Correct the wiring 3. Check the sensor
bUS	Retain		
CE	Modbus Communication Error	<ol style="list-style-type: none"> 1. Incorrect wiring 2. Communication data error caused by noise 	<ol style="list-style-type: none"> 1. Correct the wiring »Check short circuits and disconnected cables, repair if necessary 2. Check possible solution to suppress the noise
CF	Retain		
Err	Retain		
JoGE	FJOG/ RJOg Input Error	A FJOG and RJOg Run commands are received at the same time	Check the Run command from the external source for Fjog/Rjog
ACE	A1 Input signal is missing	1. A1 Input signal is missing	<ol style="list-style-type: none"> 1. Check the analog signal wiring 2. Confirm the E3-04 parameter Setting
FBPL	(water pump function) water shortage failure	<ol style="list-style-type: none"> 1. The feedback pressure is less than the water shortage detection value (F1-09) and lasts for a period of time (F1- 11) 2. The output current is less than the water shortage detection value (F1-10) and lasts for a while (F1-11) 	<ol style="list-style-type: none"> 1. Insufficient water / water shortage 2. Judging the level value is too large 3. Detection time is too short

6.3 Operation Errors

Table 6.3 Error Displays, Causes, and Possible Solutions

Keypad Display	Error Name	Cause	Possible Solution
oE02	Parameter Range Setting Error	Parameters are set outside of the possible setting range	1. Set the parameters to the proper values 2. Reset the drive
oE03	Multi-Function Input Selection Error	1. Either of Up command and Down command is not set (E1-□□= 10 or 11) 2. Either of Up command 2 and Down command 2 is not set (E1-□□=12 or 13)	Properly assign both of the UP and Down commands to the multi- function input terminal.
oE04	3-Wire Sequence Control Setting Error	Multi-Function input terminals S1 and S2 are assigned to E1- □□= 2 (3-Wire Sequence)	Do not assign multi-function input terminals S1 and S2 to E1- □□= 2 (3 - Wire Sequence)
oE05	Communication Error		
oE09	PID Control Selection Fault (When b5-00 (PID Control Setting)= 1 to 4)	1. Contradictory settings · b5-14 (PID Sleep Start Level) is not set to 0.0 · b1-02 (Stopping Method Selection) is set to 2 (DC Braking to Stop) or 3 (Coast to Stop with Timer) 2. L2-01 (Frequency Command Lower Limit) ≠ 0 when b5-00 = 1 or 2 (PID Control Enabled) 3. b5-10 (PID Output Reverse Selection) = 1 (Reverse Enabled) when b5-00 = 1 or 2 4. L2-01 = 0 when b5-00 = 3 or 4	1. Correct the parameter setting. 2. Correct the parameter setting. 3. Correct the parameter setting. 4. Correct the parameter setting.

Keypad Display	Error Name	Cause	Possible Solution
oE10	V/F Data Setting Error Incorrect d1-02, d1-04, d1-06, d1-08, d1-09 settings	V/F parameters setting incorrect	Correct the setting in d1-02, d1-04, d1-06, d1-08 and d1-09.
oE11	Carrier Frequency Setting Error	1. Contradictory settings · 6-03 (Carrier Frequency Proportional Gain) > 6 · 6-02 (Minimum Carrier Frequency) > C6-01 (Maximum Carrier Frequency) Note: If C6-03 ≤ 6, the drive operates at C6-01 2. The upper and lower limit set in C6-00 to C6-03 are contradictory.	Correct the parameter setting.
oE17	Improper setting of motor rated speed	1. The following is also set. · 6-03 (carrier frequency proportional gain) > 6 · C6-02 > C6-01 (lower carrier frequency > upper carrier frequency) (Note) When C6-03 ≤ 6, press the fixed value of C6-01 2. The upper and lower limits of C6-00~03 are set incorrectly.	Correct the parameter setting.

6.4 Operation Errors

Table 6.4 Auto-Tuning Codes, Causes, and Possible Solution

Keypad Display	Fault Name	Cause	Possible Solution
TF00	Auto-Tuning Stop	User presses STOP key during Auto-Tuning	Do not press STOP key during Auto-Tuning
TF01	Line-to Line Resistance Error	The line-to-line resistance in Auto-Tuning is negative or limited by the upper the lower limit	Check and correct motor wiring
TF07	Motor Data Error	t5-05 and t1-07 setting incorrect	Make sure the data entered to t1-05 and t1-07 is the same as the information showed on the motor nameplate. Reset the parameters.

Chapter 7 | Communication Protocol

7.1 MODBUS Communication Specification

MODBUS Communication Specification :

Item	Specifications
Interface	RS-485
Synchronously	Asynchronous
Communication Parameters	Serial transmission rate
	Data length
	Parity check: even parity / odd parity / no
	Stop bit
Communication Protocol	MODBUS Standard
How many machines can be connected	Max. 31

7.2 How to connect with controller/ PLC/ HMI

7.2.1 Connection of communication cable

1. Connect the communication cable between the device/PLC/human interface and the inverter with the power OFF. The connection terminal of the MODBUS communication cable is RJ45 port.

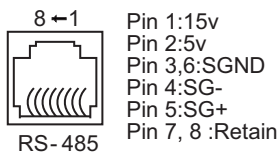

(Note) When wiring for communication, separate the main circuit wiring from other power lines and power lines. The communication wiring uses a shield wire, and the shield wire is covered and connected to the ground terminal of the inverter, and the other end is not connected and subjected to end processing, which has the effect of preventing malfunction and causing malfunction.

2. Turn on the power.
3. Use the operator to set the parameters required for communication (E6 - 06 to E6 - 10).

4. Turn off the power and check that the display of the operator disappears.
5. Turn the power on again.
6. Communicate with the device/PLC/human interface.

7.3 Information format

7.3.1 Slave site

Set the slave station address of the inverter. Please set the value from 0 to 0x1F (Hex). When the slave station address is set to 0, the master station sends an instruction to all slave stations. (broadcast transmission)

For broadcast transmission, the slave does not send a response message to the primary station. 00H: All drive broadcasts (Broadcast)

01H: For the 01th address driver

0FH: drive to the 15th address

10H: For the 16th address driver, and so on....., up to 31 (1FH).

7.3.2 Function code

Is the code used to specify the instruction. There are four types of function codes. Function Code and Data Characters

03H : Read the contents of the scratchpad

06H : Write a WORD to the scratchpad (scratchpad write) 08H : Loop test

10H : Write multiple data to the scratchpad (multiple register write)

7.4 MODBUS Data List

The MODBUS data list is as follows. The types of materials include instruction materials, surveillance materials, and broadcast transmission materials.

- **Command DATA (can be read and written)**

Loc.	Definitions	
2400H	Retain	
2401H	Operation Commands	
	Bit 0	Stop/Run (0: Stop, 1: Run)
	Bit 1	Forward/reverse (0: forward, 1: reverse)
	Bit 2	External fault EFO

Loc.	Definitions	
2401H	Bit 3	Failure return
	Bit 4	Retain
	Bit 5	Retain
	Bit 6	Retain
	Bit 7	Retain
	Bit 8	Multi-function terminal 1 (1: ON)
	Bit 9	Multi-function terminal 2 (1: ON)
	Bit 10	Multi-function terminal 3 (1: ON)
	Bit 11	Multi-function terminal 4 (1: ON)
	Bit 12	Multi-function terminal 5 (1: ON)
	Bit 13	Multi-function terminal 6 (1: ON)
2402H	Frequency command (unit:	

- **Monitor DATA (read only)**

Loc.	Definitions	
2420H	Retain	
2421H	Operational state	
	Bit 0	1: In operation
	Bit 1	1: Reverse running
	Bit 2	1: Zero speed
	Bit 3	1: malfunction
	Bit 4	1: Warning
	Bit 5	1: Consistent frequency
	Bit 6	1: The inverter is ready to run.
	Bit 7	1: Frequency provided by communication
	Bit 8	1: Operation provided by communication
	BIT 11~15	Retain
2422H	Frequency command (Unit 0.01Hz)	
2423H	Output frequency (Unit 0.01Hz)	
2424H	Output current (Unit 0.1A)	
2425H	Output voltage (Unit 0.1V)	
2426H	DC voltage (Unit 0.1V)	
2427H	Warning Description	

Loc.	Definitions	
2428H	Malfunction Description	
2429H	Multi-function input and output status	
	Bit 0	1: Multi-function terminal 1 ON
	Bit 1	1: Multi-function terminal 2 ON
	Bit 2	1: Multi-function terminal 3 ON
	Bit 3	1: Multi-function terminal 4 ON
	Bit 4	1: Multi-function terminal 5 ON
	Bit 5	1: Multi-function terminal 6 ON
	BIT 8~10	Retain
	BIT 12	1: Relay1 ON
	BIT 14	1: PH1 ON
BIT 15	Retain	
242AH	AI1 Input(0 correspond 0V or 0mA, 1000 correspond 10V or 20mA)	
242CH	Retain	
242DH	AO1 Input (0 correspond 0V, 1000 correspond 10V)	

● **Warning Description (2427H)**

Value	Contents	Value	Contents	Value	Contents
0	No warning	13	Retain	26	UT1 (Motor low torque1)
1	EF0 (Communication error)	14	Retain	27	Retain
2	EF1 (external warning 1)	15	Retain	28	Retain
3	EF2 (external warning 2)	16	Retain	29	Retain
4	EF3 (external warning 3)	17	Retain	30	Retain
5	EF4 (external warning 4)	18	FbH (PID feedback is too high)	31	BB (Output shutoff)
6	EF5 (external warning 5)	19	FbL (PID feedback is too low)	32	OH2 (Inverter OH2 Warning)
7	EF6 (external warning 6)	20	OH (Inverter overheating)	33	HCA (Overcurrent)

Value	Contents	Value	Contents	Value	Contents
8	Retain	21	Retain	34	DNE (Drive is invalid)
9	Retain	22	OT1 (Motor over torque 1)	35	Retain
10	Retain	23	Retain	36	CE (MODBUS communication is abnormal)
11	Retain	24	OV (Overvoltage warning)	37	Retain
12	Retain	25	UV (Low voltage warning)	38	Retain

● **Fault description (2428H)**

Value	Contents	Value	Contents	Value	Contents
0	Functional	31	Retain	62	Retain
1	GF (ground short circuit)	32	Retain	63	SEr (speed search is abnormal)
2	OVA (Accelerated overvoltage)	33	OH (Inverter overheating)	64	Retain
3	OVD (Deceleration over voltage)	34	Retain	65	OH1 (motor overheated)
4	OVC (fixed speed overvoltage)	35	Retain	66	CPF02
5	OCA (acceleration overcurrent)	36	OL1 (motor overload)	67	CPF03
6	OCd (deceleration over current)	37	OL2 (Inverter overload)	68	CPF04
7	OCC (overcurrent during operation)	38	Retain	69	CPF05
8	EF(overcurrent during operation)	39	OT1 (motor over torque 1)	70	CPF06
9	SC (short circuit)	40	Retain	71	CPF07
10	Retain	41	UT1 (motor low torque 1)	72	Retain

Value	Contents	Value	Contents	Value	Contents
11	Retain	42	Retain	73	JOGE (FJOG, RJOG At the same time)
12	Retain	43	Retain	74	-OFF-
13	Retain	44	UV1(DC voltage is too low)	75	Retain
14	Retain	45	UV2	76	Retain
15	Retain	46	PF (input phase)	77	Retain
16	Retain	47	LF1 (output phase loss)	78	Retain
17	EF0 (communication exception)	48	Retain	79	Retain
18	EF1 (external fault 1)	49	Retain	80	Retain
19	EF2 (external fault2)	50	Retain	81	Retain
20	EF3 (external fault 3)	51	Retain	82	Retain
21	EF4 (external fault 4)	52	Retain	83	Retain
22	EF5 (external fault 5)	53	Retain	84	Retain
23	EF6 (external fault 6)	54	FbH (PID feedback is too high)	85	Retain
24	Retain	55	FbL (PID feedback is too low)	86	Retain
25	Retain	56	bUS (Communication card is abnormal)	87	Retain
26	Retain	57	CE (communication error)	88	Retain
27	Retain	58	CF (control fault)	89	Retain
28	Retain	59	Err (EEPROM error)	90	Retain
29	Retain	60	Retain	91	Retain
30	Retain	61	Retain		

Mod The parameter Modbus address corresponding to the inverter is as follows

parameter	Address	parameter	Address	parameter	Address
A1-00	0x0000	A2-00	0x0080	A2-11	0x008B
A1-01	0x0001	A2-01	0x0081	A2-12	0x008C
A1-02	0x0002	A2-02	0x0082	A2-13	0x008D
A1-03	0x0003	A2-03	0x0083	A2-14	0x008E
A1-04	0x0004	A2-04	0x0084	A2-15	0x008F
A1-05	0x0005	A2-05	0x0085	A2-32	0x00A0
A1-07	0x0007	A2-06	0x0086		
		A2-07	0x0087		
		A2-08	0x0088		
		A2-09	0x0089		
		A2-10	0x008A		

parameter	Address	parameter	Address	parameter	Address
b1-00	0x0100	b2-00	0x0180	b3-00	0x0200
b1-01	0x0101	b2-01	0x0181	b3-01	0x0201
b1-02	0x0102	b2-02	0x0182	b3-02	0x0202
b1-03	0x0103	b2-03	0x0183	b3-03	0x0203
b1-05	0x0105			b3-04	0x0204
b1-06	0x0106			b3-05	0x0205
b1-07	0x0107				
b1-09	0x0109				
b1-10	0x010A			b4-00	0x0280
b1-12	0x010C			b4-01	0x0281
b1-13	0x010D				

parameter	Address	parameter	Address	parameter	Address
b5-00	0x0300	b5-21	0x0315	b9-02	0x0502
b5-01	0x0301	b5-22	0x0316		
b5-02	0x0302	b5-23	0x0317		
b5-03	0x0303	b5-24	0x0318		
b5-04	0x0304	b5-25	0x0319		
b5-05	0x0305	b5-26	0x031A		
b5-06	0x0306	b5-27	0x031B		
b5-07	0x0307	b5-28	0x031C		
b5-08	0x0308	b5-29	0x031D		
b5-09	0x0309	b5-30	0x031E		
b5-10	0x030A				
b5-11	0x030B				
b5-12	0x030C				
b5-13	0x030D				
b5-14	0x030E				
b5-15	0x030F				
b5-16	0x0310				
b5-17	0x0311				
b5-18	0x0312				
b5-19	0x0313				
b5-20	0x0314				

parameter	Address	parameter	Address	parameter	Address
C1-00	0x0580	C2-00	0x0600	C3-00	0x0680
C1-01	0x0581	C2-01	0x0601	C3-02	0x0682
C1-02	0x0582	C2-02	0x0602		
C1-03	0x0583	C2-03	0x0603	C5-00	0x0780
C1-08	0x0588			C5-01	0x0781
C1-11	0x058B				
C1-12	0x058C			C6-00	0x0800

parameter	Address	parameter	Address	parameter	Address
L1-00	0x0880	L1-13	0x088D	L4-00	0x0A00
L1-01	0x0881	L1-14	0x088E	L4-01	0x0A01
L1-02	0x0882	L1-15	0x088F	L4-02	0x0A02
L1-03	0x0883	L1-16	0x0890	L4-03	0x0A03
L1-04	0x0884			L4-04	0x0A04
L1-05	0x0885	L2-00	0x0900		
L1-06	0x0886	L2-01	0x0901	L6-00	0x0B00
L1-07	0x0887			L6-01	0x0B01
L1-08	0x0888	L3-00	0x0980	L6-02	0x0B02
L1-09	0x0889	L3-01	0x0981		
L1-10	0x088A	L3-02	0x0982		
L1-11	0x088B	L3-03	0x0983		

parameter	Address	parameter	Address	parameter	Address
d1-00	0x0B80	d2-00	0x0C00	E1-00	0x0D00
d1-01	0x0B81	d2-01	0x0C01	E1-01	0x0D01
d1-02	0x0B82	d2-02	0x0C02	E1-02	0x0D02
d1-03	0x0B83	d2-03	0x0C03	E1-03	0x0D03
d1-04	0x0B84	d2-04	0x0C04	E1-04	0x0D04
d1-05	0x0B85	d2-05	0x0C05	E1-05	0x0D05
d1-06	0x0B86	d2-06	0x0C06	E1-08	0x0D08
d1-07	0x0B87	d2-07	0x0C07	E1-09	0x0D09
d1-08	0x0B88	d2-10	0x0C0A	E2-00	0x0D80
d1-09	0x0B89			E3-00	0x0E00
d1-15	0x0B8F			E3-01	0x0E01
d1-20	0x0B94			E3-02	0x0E02

parameter	Address	parameter	Address	parameter	Address
E3-03	0x0E03	E4-03	0x0E83	E6-09	0x0F89
E3-05	0x0E05	E6-05	0x0F85	E6-10	0x0F8A
E3-13	0x0E0D	E6-06	0x0F86	E6-11	0x0F8B
E4-01	0x0E81	E6-07	0x0F87	E6-12	0x0F8C
E4-02	0x0E82	E6-08	0x0F88	E6-13	0x0F8D

parameter	Address	parameter	Address	parameter	Address
P1-00	0x1000	P2-00	0x1080	P3-00	0x1100
P1-01	0x1001	P2-01	0x1081	P3-01	0x1101
P1-05	0x1005	P2-03	0x1083	P3-02	0x1102
		P2-05	0x1085	P3-03	0x1103
		P2-10	0x108A	P3-04	0x1104
				P3-05	0x1105
				P3-06	0x1106
				P3-07	0x1107
				P3-08	0x1108
				P3-09	0x1109
				P3-10	0x110A

parameter	Address	parameter	Address	parameter	Address
P4-00	0x1180	P5-00	0x1200	P6-00	0x1280
P4-01	0x1181	P5-01	0x1201	P6-01	0x1281
P4-02	0x1182	P5-02	0x1202	P6-02	0x1282
P4-03	0x1183				
P4-04	0x1184				
P4-05	0x1185				
P4-06	0x1186				

parameter	Address	parameter	Address	parameter	Address
P7-00	0x1300	n1-00	0x1380	t1-07	0x1887
P7-01	0x1301	n1-01	0x1381	t1-09	0x1889
P7-02	0x1302	n3-04	0x1484	t1-12	0x188C
P7-03	0x1303	n3-06	0x1486		
P7-04	0x1304	t1-01	0x1881		
P7-07	0x1307	t1-02	0x1882		
P7-09	0x1309	t1-03	0x1883		
P7-10	0x130A	t1-04	0x1884		
P7-11	0x130B	t1-05	0x1885		
P7-14	0x130E	t1-06	0x1886		

parameter	Address	parameter	Address	parameter	Address
o1-00	0x1680	o2-01	0x1701	o4-00	0x1800
o1-02	0x1682	o2-02	0x1702	o4-06	0x1806
o1-03	0x1683	o2-03	0x1703		
o1-04	0x1684	o2-04	0x1704		
		o2-05	0x1705		
		o2-06	0x1706		

parameter	Address	parameter	Address	parameter	Address
U1-00	0x1D00	U2-09	0x1D89	U3-08	0x1E08
U1-01	0x1D01	U2-10	0x1D8A	U3-09	0x1E09
U1-02	0x1D02	U2-13	0x1D8D	U3-10	0x1E0A
U1-03	0x1D03	U2-14	0x1D8E	U3-11	0x1E0B
U1-04	0x1D04	U2-15	0x1D8F	U3-12	0x1E0C
U1-05	0x1D05	U2-17	0x1D91	U3-13	0x1E0D
U1-06	0x1D06	U2-18	0x1D92	U3-14	0x1E0E
U1-07	0x1D07	U2-19	0x1D93	U3-15	0x1E0F
U1-08	0x1D08	U2-20	0x1D94	U3-17	0x1E11
U1-09	0x1D09	U2-21	0x1D95	U4-00	0x1E80
U1-10	0x1D0A	U2-22	0x1D96	U4-01	0x1E81
U1-11	0x1D0B	U2-23	0x1D97	U4-02	0x1E82
U1-12	0x1D0C	U2-24	0x1D98	U4-03	0x1E83
U1-16	0x1D10	U2-27	0x1D9B	U4-08	0x1E88
U1-17	0x1D11	U2-28	0x1D9C		
U1-19	0x1D13	U2-29	0x1D9D		
U1-20	0x1D14	U2-31	0x1D9F		
U1-21	0x1D15	U2-32	0x1DA0		
U2-00	0x1D80	U2-33	0x1DA1		
U2-01	0x1D81	U2-34	0x1DA4		
U2-02	0x1D82	U2-35	0x1DA5		
U2-03	0x1D83	U2-36	0x1DA6		
U2-04	0x1D84	U2-37	0x1DA7		
U2-05	0x1D85	U3-00	0x1E00		
U2-06	0x1D86	U3-02	0x1E02		
U2-07	0x1D87	U3-06	0x1E06		
U2-08	0x1D88	U3-07	0x1E07		

Edit Date			Edit Date		
Parameter			Parameter		
A1-00			b3-04		
A1-01			b3-05		
A1-02			b5-00		
A1-03			b5-01		
A1-04			b5-02		
A1-05			b5-03		
A2-00			b5-04		
A2-01			b5-05		
A2-02			b5-06		
A2-03			b5-07		
A2-04			b5-08		
A2-05			b5-09		
A2-06			b5-10		
A2-07			b5-11		
A2-08			b5-12		
A2-09			b5-13		
A2-10			b5-14		
A2-11			b5-15		
A2-12			b5-16		
A2-13			b5-17		
A2-14			b5-18		
A2-15			b5-19		
A2-32			b5-20		
b1-00			b5-21		
b1-01			b5-22		
b1-02			b5-23		
b1-03			b5-24		
b1-05			b5-25		
b1-06			b5-26		
b1-09			b5-27		
b1-10			b5-28		
b1-11			b8-00		
b2-00			C1-00		
b2-01			C1-01		
b2-02			C1-02		
b2-03			C1-03		
b3-00			C1-08		
b3-01			C2-00		
b3-02			C2-01		
b3-03			C2-02		

Edit Date			Edit Date		
Parameter			Parameter		
C2-03			d1-05		
C3-00			d1-06		
C5-00			d1-07		
C5-01			d1-08		
C6-00			d1-09		
C6-01			d2-00		
C6-02			d2-01		
C6-03			d2-02		
L1-00			d2-03		
L1-01			d2-04		
L1-02			E1-00		
L1-03			E1-01		
L1-04			E1-02		
L1-05			E1-03		
L1-06			E1-04		
L1-07			E1-05		
L1-08			E2-00		
L1-09			E3-00		
L1-10			E3-01		
L1-11			E3-02		
L1-12			E3-03		
L1-13			E3-05		
L1-14			E4-00		
L1-15			E4-01		
L1-16			E4-02		
L2-00			E4-03		
L2-01			E6-00		
L3-00			E6-01		
L3-01			E6-02		
L3-03			E6-03		
L4-00			E6-04		
L4-01			E6-05		
L4-02			E6-06		
L4-03			E6-07		
L4-04			E6-08		
d1-00			P1-00		
d1-01			P1-01		
d1-02			P1-05		
d1-03			P2-00		
d1-04			P2-01		

Edit Date Parameter			Edit Date Parameter		
P2-02			o4-01		
P2-03			o4-06		
P2-05			o4-07		
P3-00			o4-08		
P3-01			t1-02		
P3-02			t1-03		
P3-03			t1-04		
P3-05			t1-05		
P3-06			t1-06		
P3-07			t1-07		
P3-08			t1-10		
P3-11			t1-12		
P4-00					
P4-01					
P4-02					
P4-03					
P4-04					
P5-00					
P5-01					
P5-02					
P6-00					
P6-01					
P6-02					
P7-00					
P7-01					
P7-02					
P7-03					
P7-04					
P7-05					
P7-09					
P7-12					
o1-00					
o2-01					
o2-02					
o2-03					
o2-05					
o2-06					
o3-00					
o3-01					
o4-00					

ALL INDIA SERVICE NETWORK

- Regional Offices
- 🏭 Works
- ⚙️ Service Centre: Drives
- ⊗ Service Centre: Servo Motors

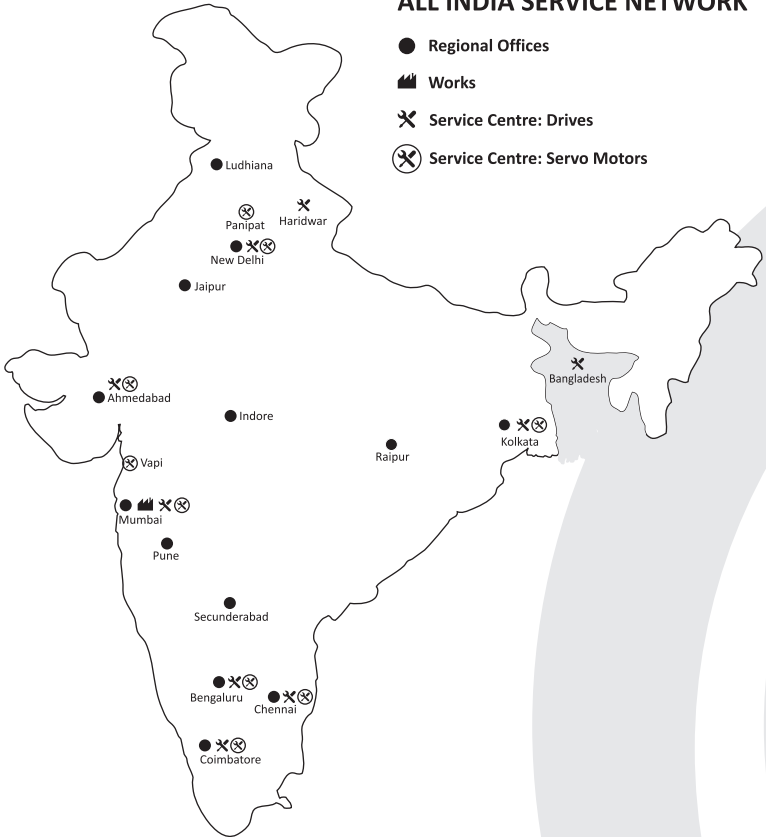

BB ServiceLINE™
Customer Service Helpdesk for Industrial Systems

+91 22 - 2763 7290 | service@bharatbijlee.com



Bharat Bijlee Drives & Automation

Mobile App for Troubleshooting and Maintenance of Drives & Servo Motors

Download for free from Google Play Store

B Bharat Bijlee

REGISTERED OFFICE

Electric Mansion, 6th Floor,
Appasaheb Marathe Marg,
Prabhadevi, Mumbai 400 025
T: +91 22 2430 6237 / 6375
E: info@bharatbijlee.com
CIN: L31300MH1946PLC005017

WORKS

No. 2, MIDC Thane-Belapur Road, Airoli,
Navi Mumbai 400 708
T: +91 22 2763 7200 / +91 22 2760 0401
E: drivesales@bharatbijlee.com
www.bharatbijlee.com